

作成承認印

配布許可印



AF Zoom-Nikkor 35-105mm f/3.5-4.5 D

REPAIR MANUAL

修 理 指 針

Nikon | NIKON CORPORATION
Tokyo, Japan

© Copyright 1994
ALL RIGHTS RESERVED
無断転載を禁ず!!

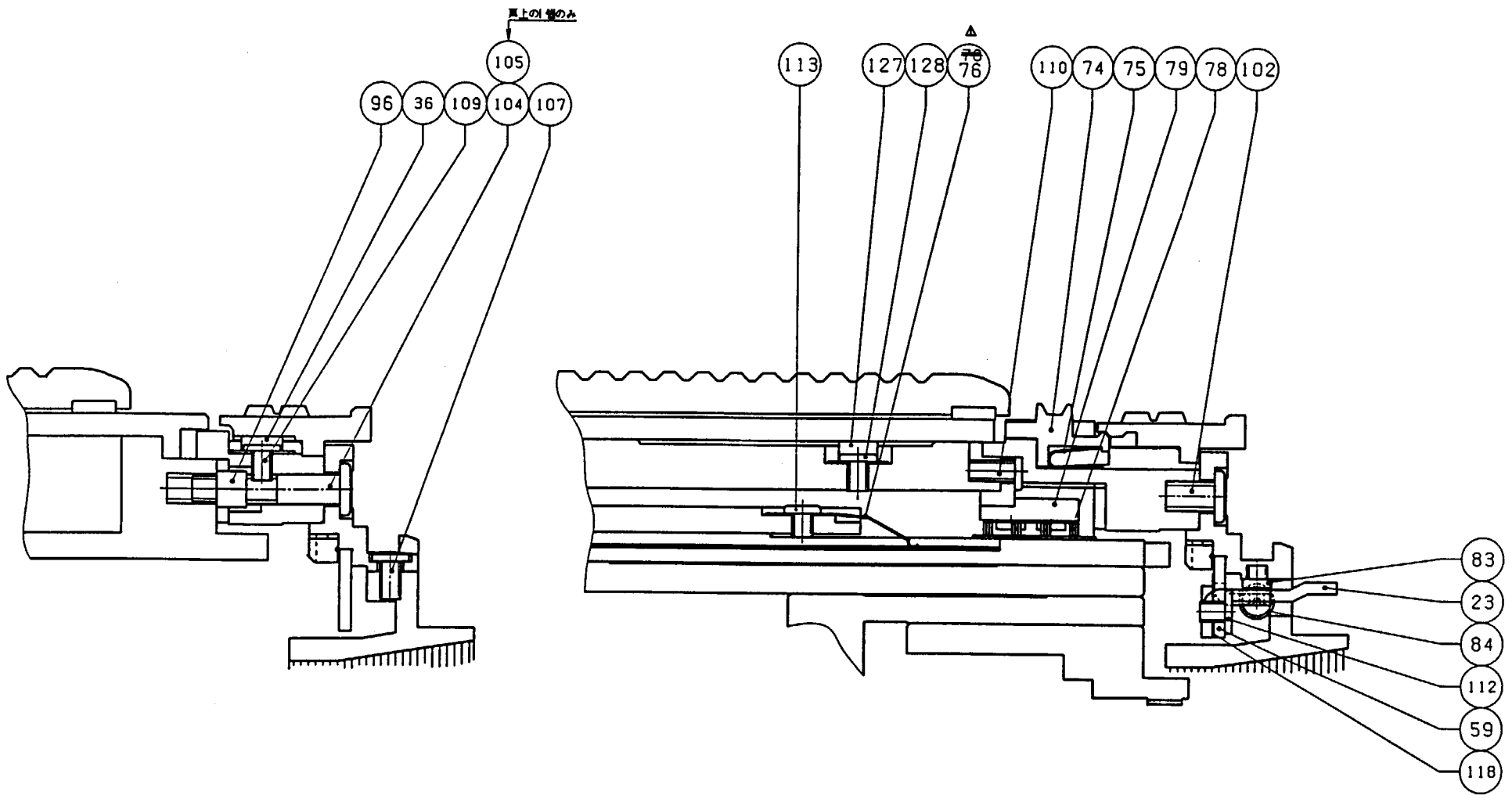

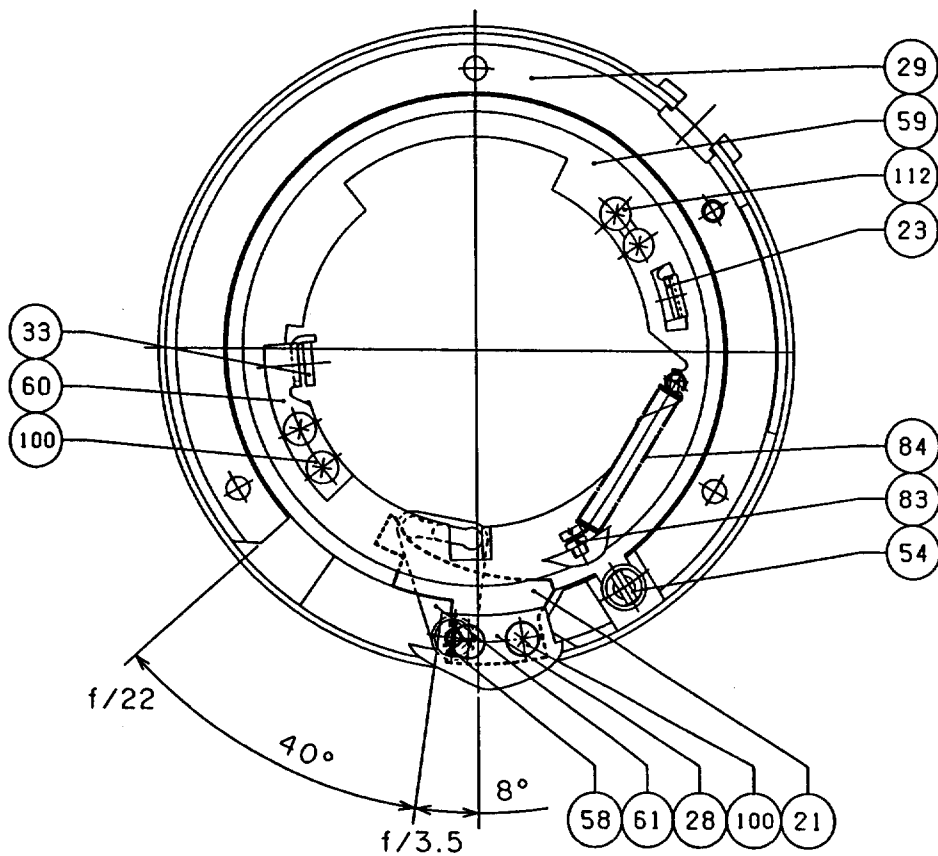
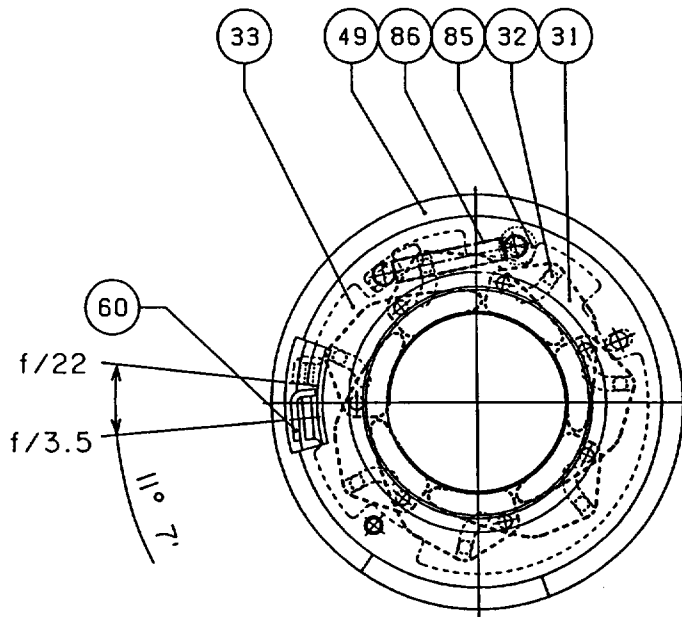

DISASSEMBLING / ASSEMBLING / ADJUSTMENT

1. DISASSEMBLING PROCEDURE

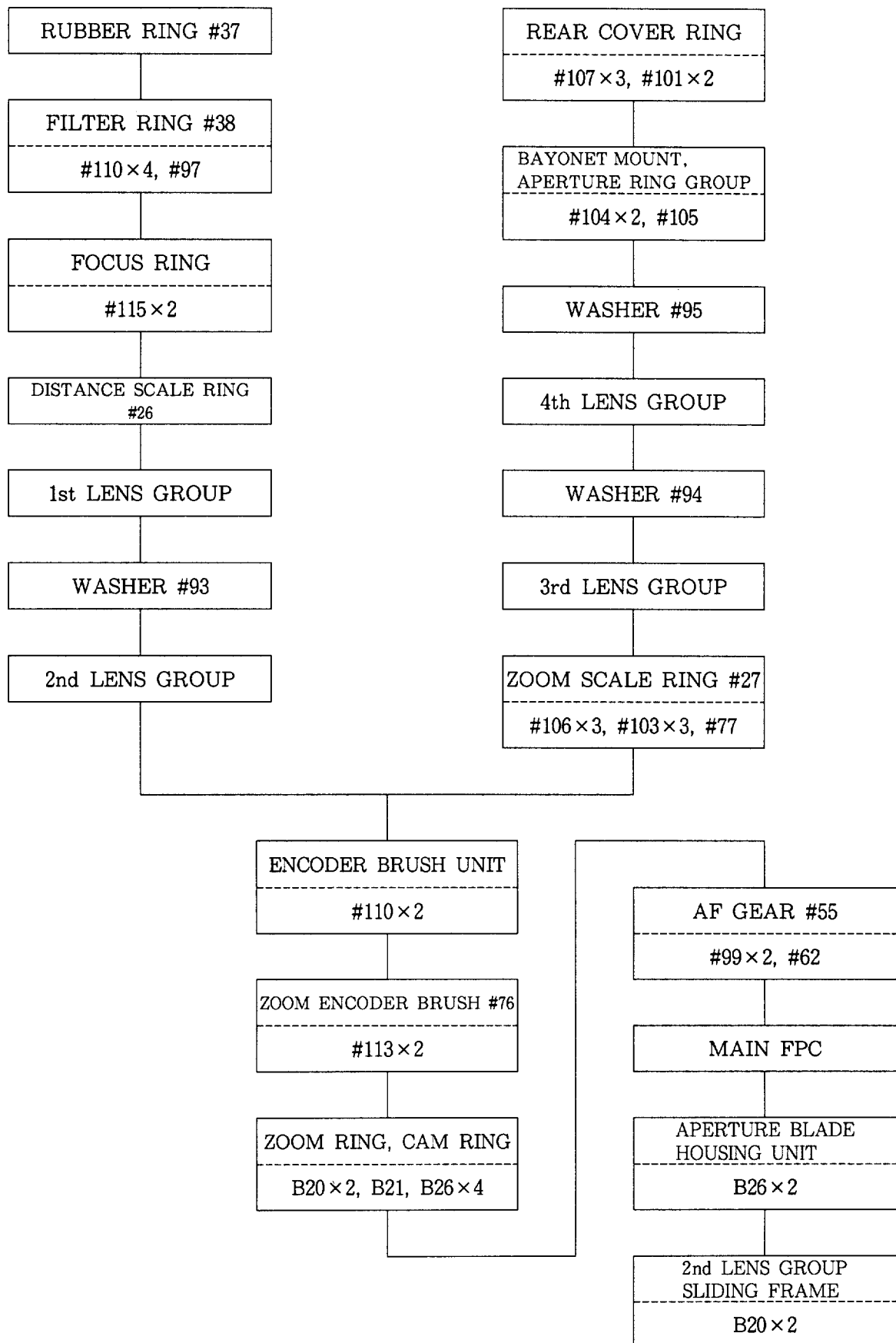

2. ASSEMBLING / ADJUSTMENT

CAM RING, 2nd LENS GROUP SLIDING FRAME

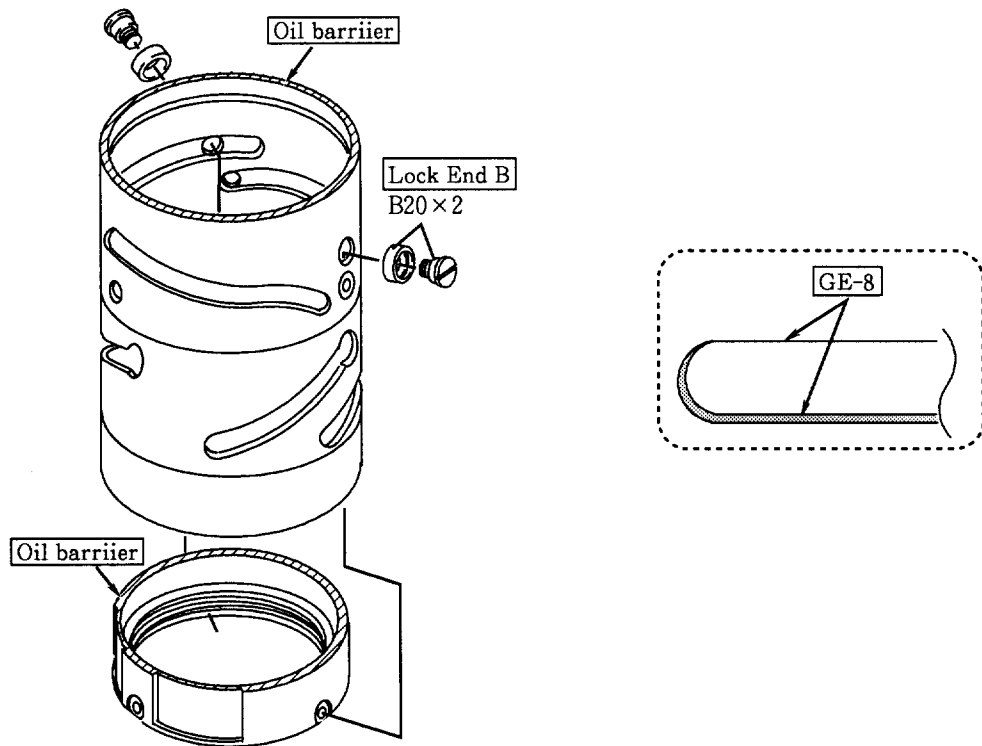

APERTURE BLADE GROUP

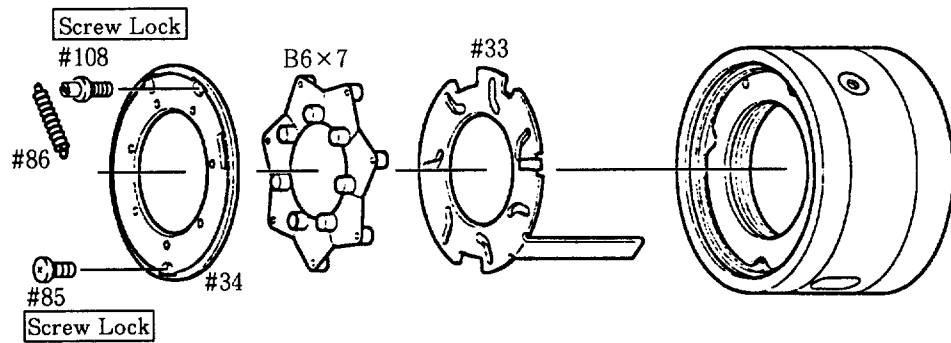

APERTURE BLADE HOUSING UNIT

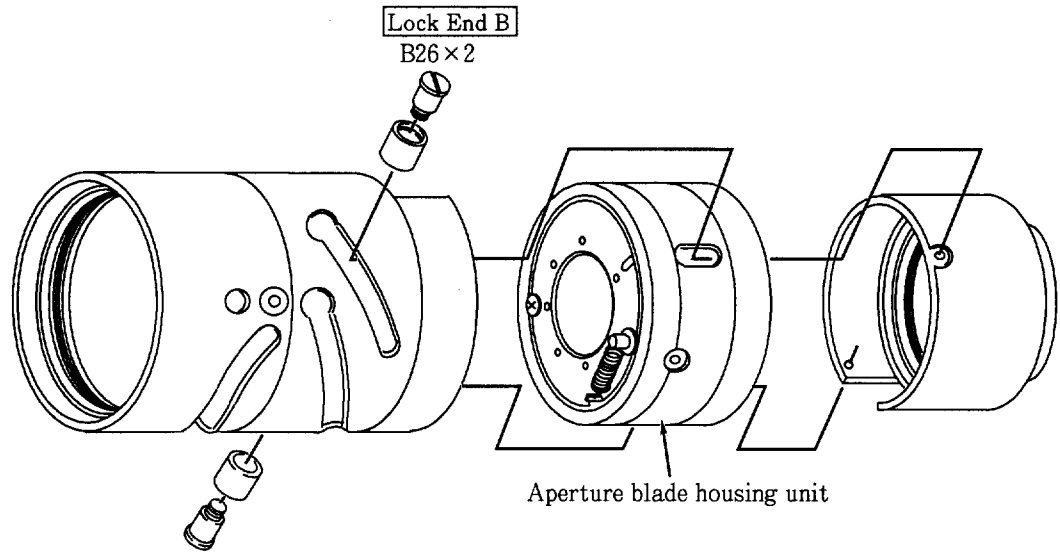

MAIN FPC, AF GEAR

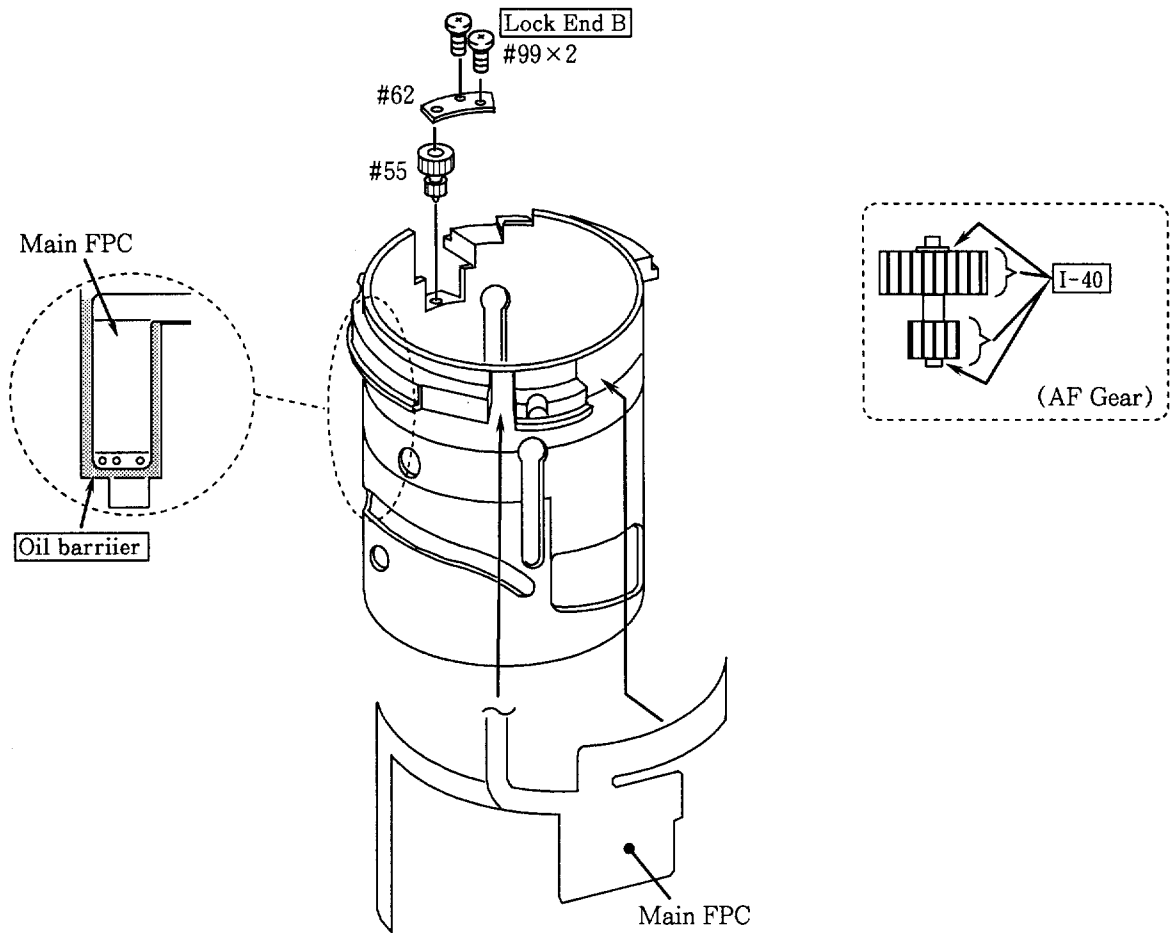

CAM RING GROUP

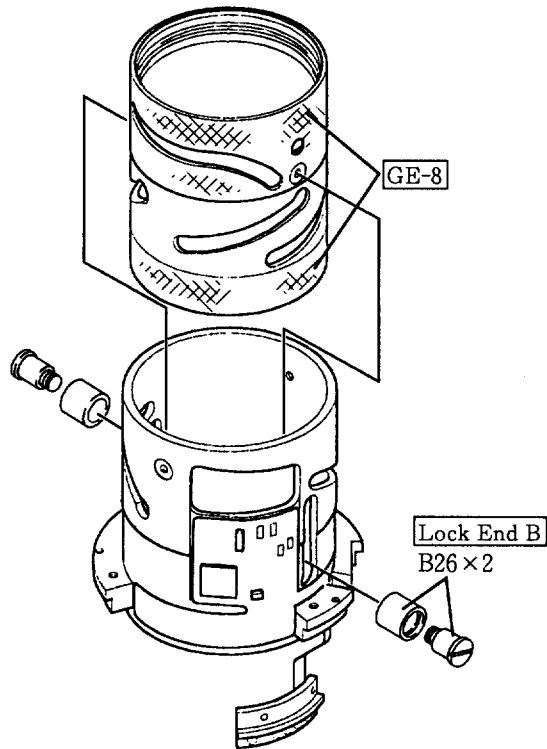

ZOOM RING

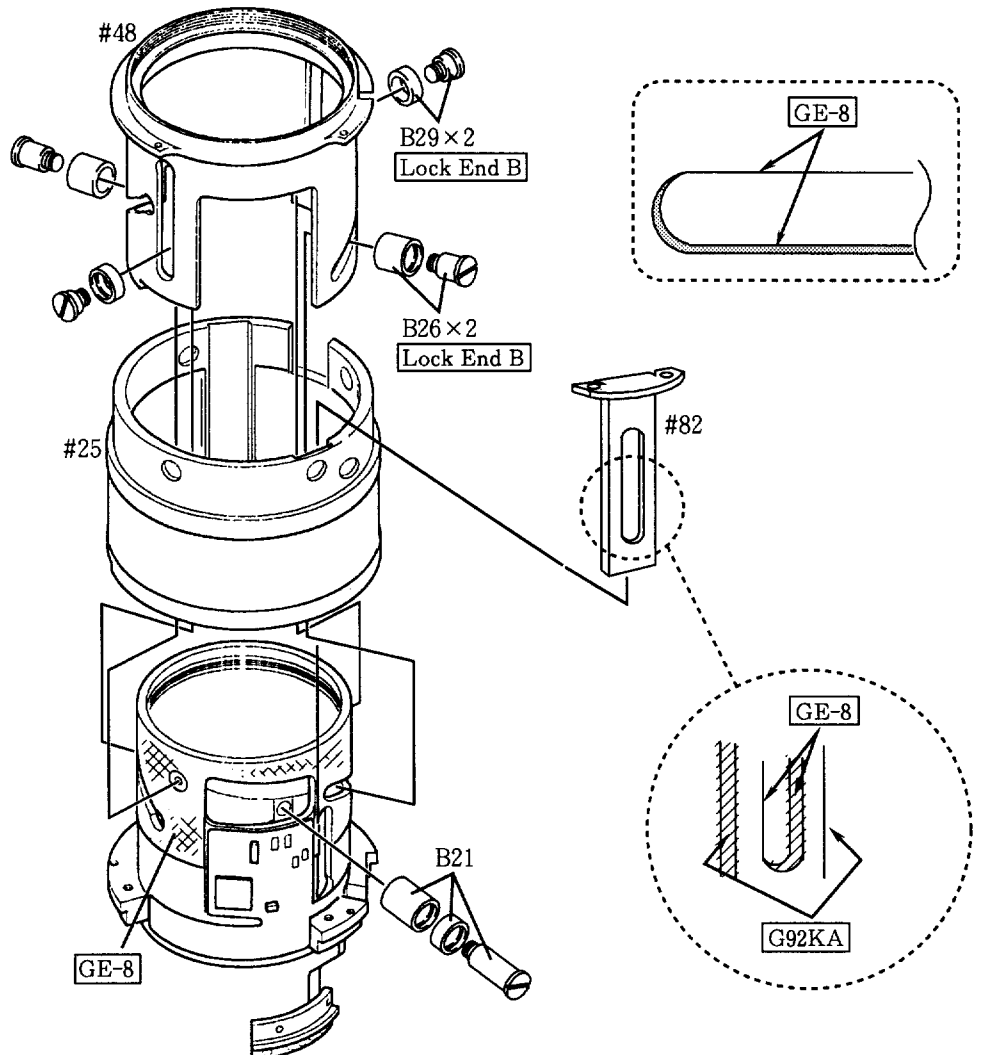

ADJUSTMENT OF ZOOM ENCODER BRUSH POSITION

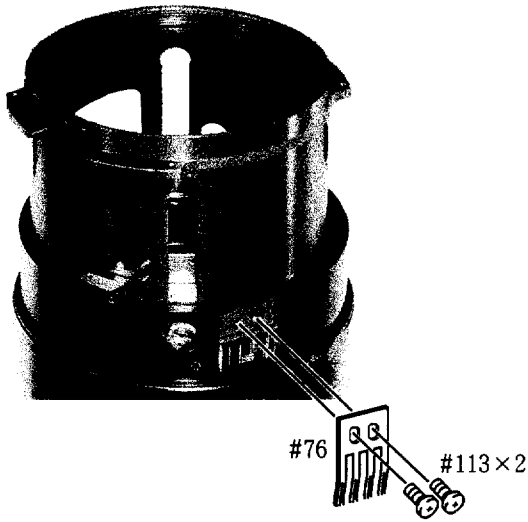

① Unfasten screws #113x2 and let the brush tip come into contact with the line as shown in the figure.

② Fasten screws #113x2 and turn the zoom ring several times to check the location of the brush.

③ Secure screws #113x2 using Screw Lock.

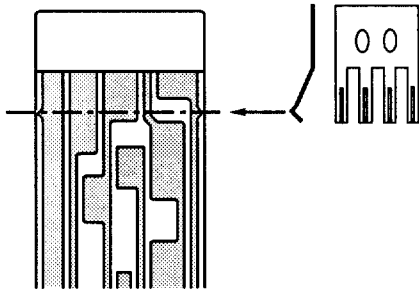

ZOOM SCALE RING

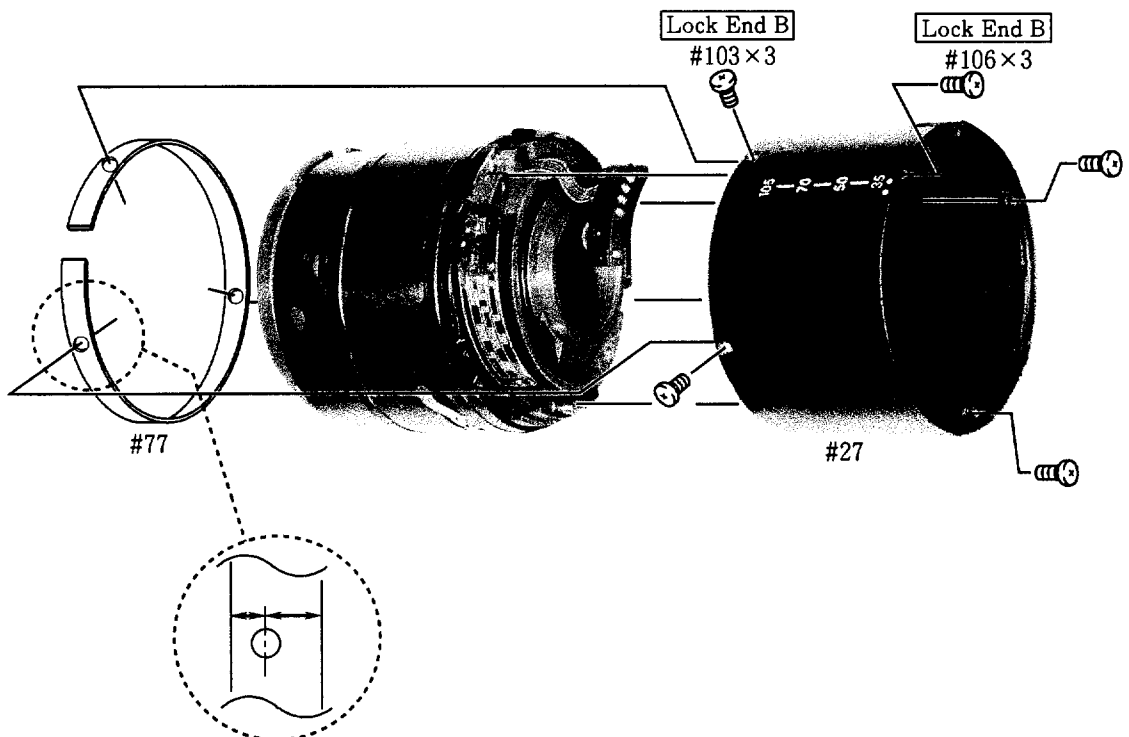

NAME RING

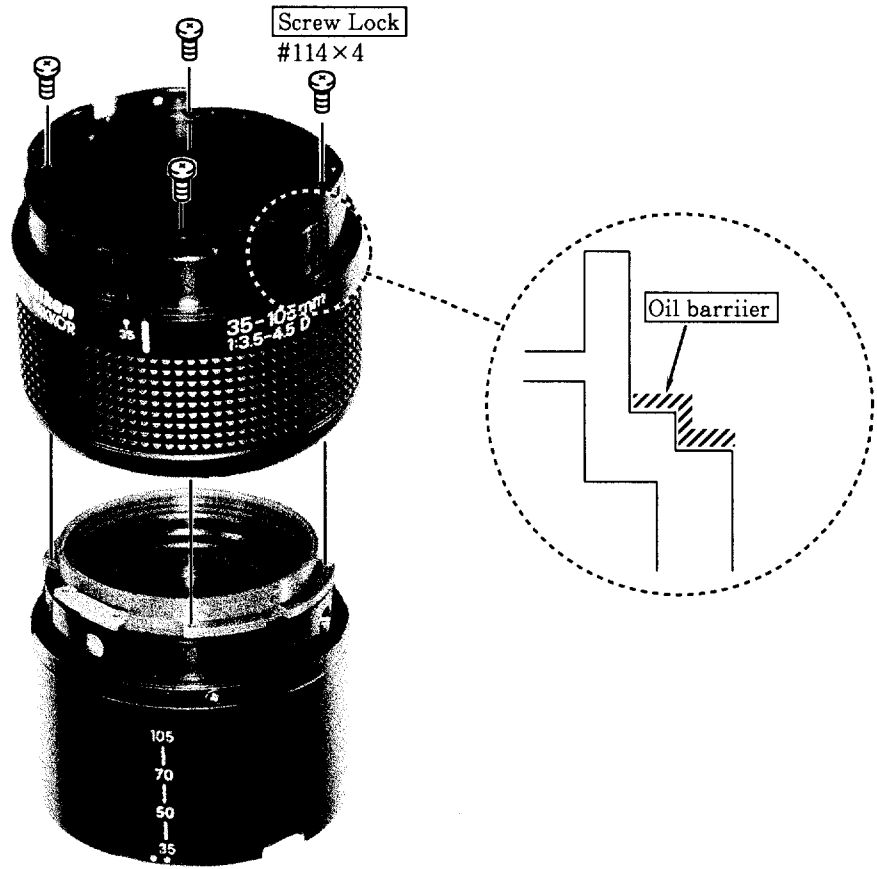

FOCUS RING, DISTANCE SCALE RING

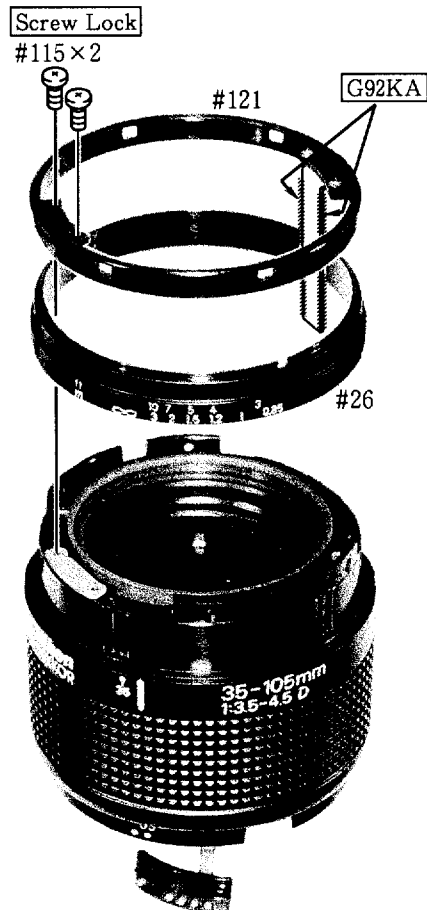

FILTER RING

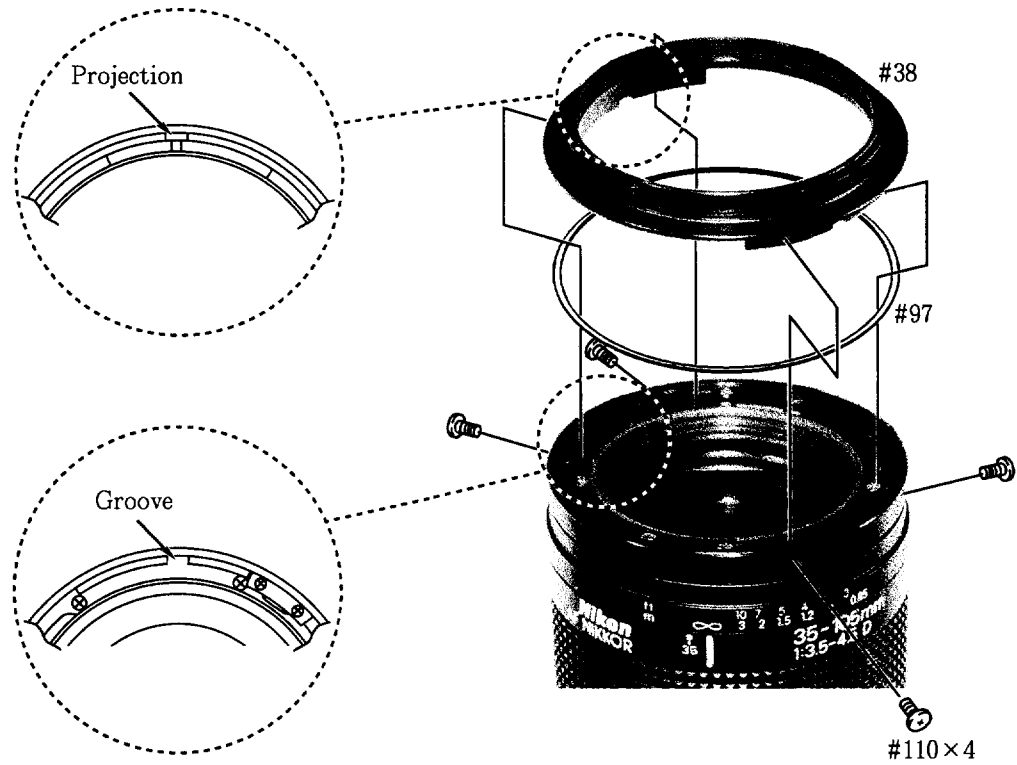

ADJUSTMENT OF ENCODER BRUSH POSITION

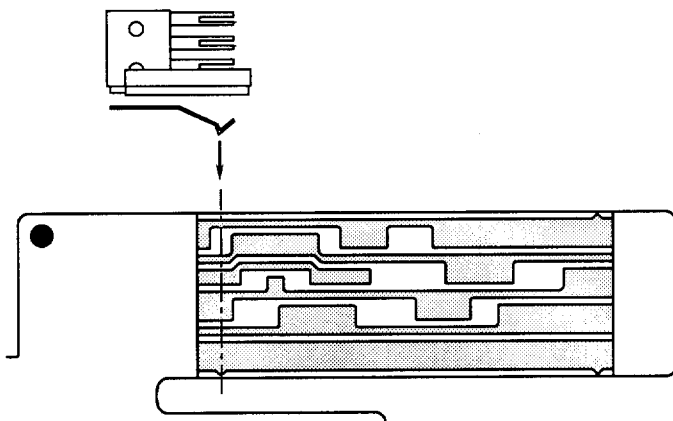
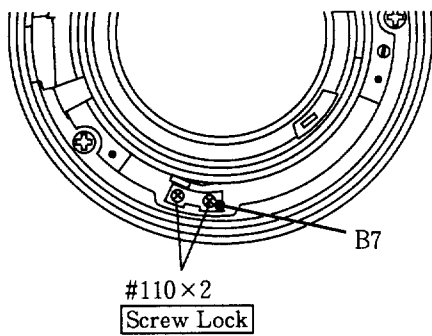

- ① Attach focus ring to the infinity stopper.
- ② Unfasten screws #110×2 and let the brush tip come into contact with the line as shown in the figure.
- ③ Fasten screws #110×2 and turn the focus ring several times to check the location of the brush.
- ④ Secure screws #110×2 using Screw Lock.

BAYONET MOUNT GROUP

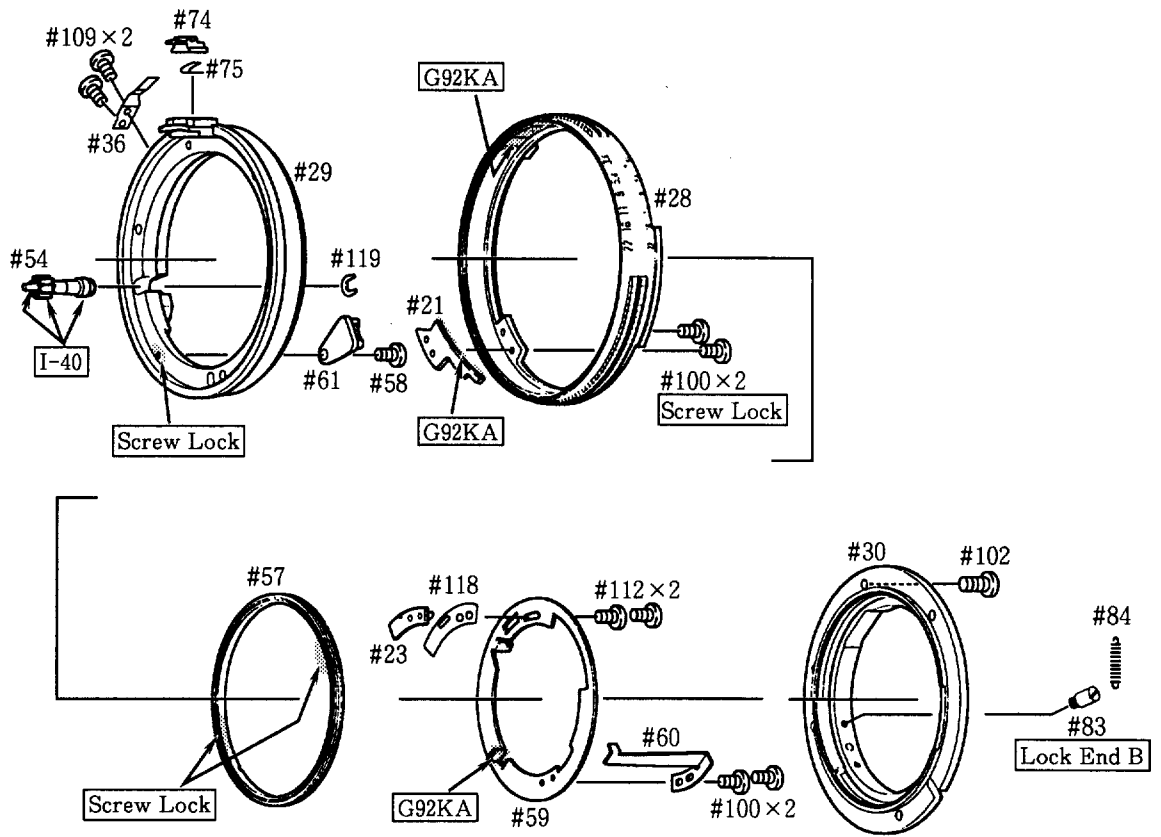

MOUNTING BAYONET MOUNT GROUP

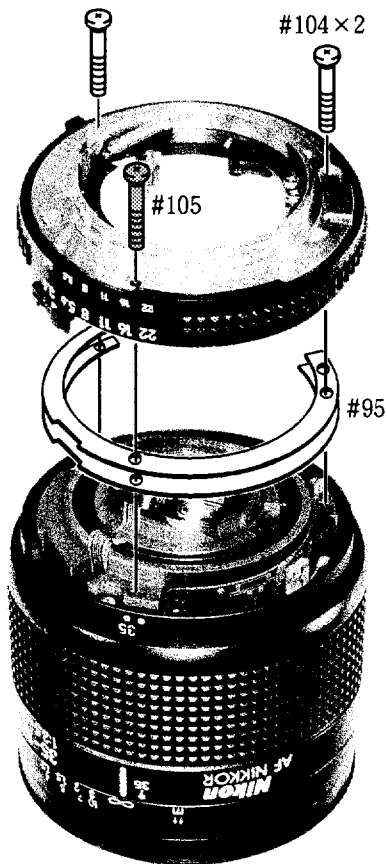

ADJUSTMENT OF APERTURE OPENING

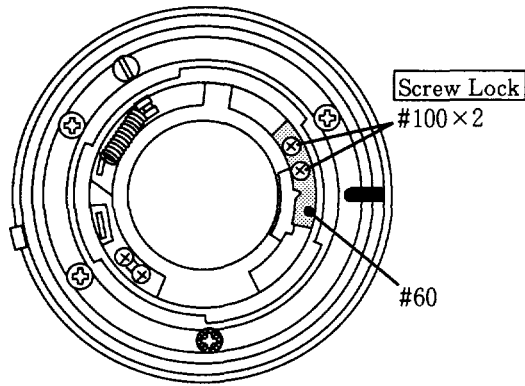

- ① Unfasten screws #100×2 and move part #60 to adjust the aperture diameter.
As a guide to adjustment, the full aperture (f/3.5) should be the same size as the inside aperture of part #33.
 - Aperture diameter should be within the allowable range when the diaphragm ring is rotated forward and backward.
 - Aperture lever should be within the allowable range when the aperture lever is snapped by your finger.
- ② After adjustment, secure screws #100×2 using Screw Lock.

Aperture setting	Inscribed circle diameter (mm)	Tolerance (mm)
3.5	16.60	17.60 ~ 15.71
4	14.57	15.74 ~ 13.49
5.6	10.17	11.42 ~ 9.06
8	7.16	8.04 ~ 6.38
11	5.06	5.90 ~ 4.33
16	3.58	4.17 ~ 3.07
22	2.53	2.95 ~ 2.17

ADJUSTMENT OF APERTURE LEVER POSITION

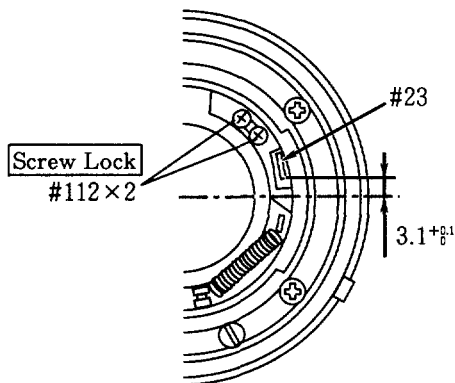

Unfasten screws #112×2 to adjust the position of the aperture lever #23 so that it comes into the rated value of $3.1^{+0.1}$ to bring the aperture diameter within rated value at full aperture.
After adjustment, fix screws #112×2 using Screw Lock.

Reference : When adjusting the rated value of $3.1^{+0.1}$, set the aperture ring to f/3.5 and mount the tool J18004-1 on the bayonet mount. It becomes much easier to adjust if you mount the aperture lever #23 based on the groove of the tool as a reference.

ADJUSTMENT OF DISTANCE AMONG G10 AND G11 LENS

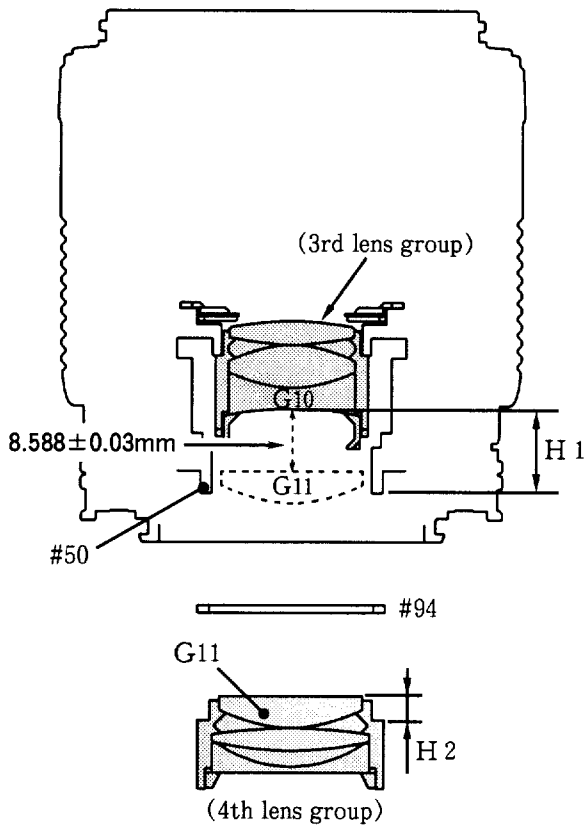

- ① Mount the 3rd lens group and attach zoom ring to the wide stopper.
- ② Set the lens on the measuring stand with the bayonet mount facing up.
- ③ Measure the length (H1) from G10 lens to the 4th lens group mounting surface of #50 using the digital micrometer.
- ④ Measure the length (H2) from G11 lens to the mounting surface of the 4th lens group using the digital micrometer.
- ⑤ Calculate the following equation. (Unit: mm)
 $8.588 - (H1 - H2) = \text{Thickness of washer \#94}$
- ⑥ Decrease the thickness of washer #94 so that the value becomes equal to the value listed above.
- ⑦ Mount the washer #94 and the 4th lens group.

1st AND 2nd LENS GROUP

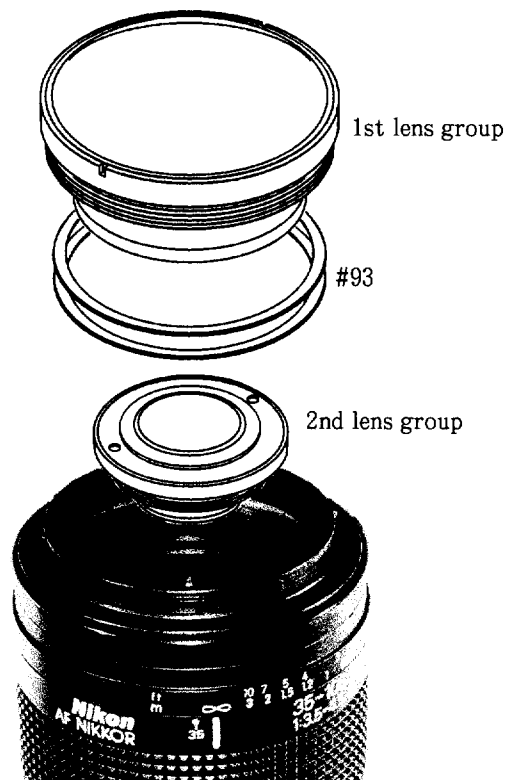

RUBBER RING #37

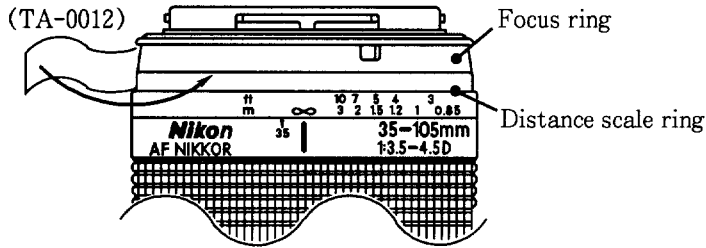
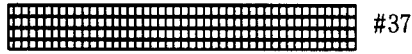

1. Attach focus ring to infinity stopper.
2. Align the ∞ mark on focus ring to index.
3. Secure focus ring and distance scale ring with adhesive tape (TA-0012). Wrap the adhesive tape one round.
4. Attach the rubber ring #37.

ADJUSTMENT OF SHIFE FOCUS (TELE AND WIDE)

1. Align the ∞ mark on focus ring to index. Set aperture to full aperture.
2. Read the value on both Wide and Tele sides respectively.
3. Calculate the following equation.

$$(A - B) \div 1.83 = C$$

A = Value of Tele side (mm)

B = Value of Wide side (mm)

C = Amount (mm) of adjustment of 1st lens group washer #93

4. Adjust the thickness of washer #93 by the value C calculated from the above equation. If the value C is positive, thicken the washer by the value, and if negative, thin the washer.

Note : Insert thin washer between thick washers when mounting washer #93.

(Refer to page L10.)

ADJUSTMENT OF BACK FOCUS

1. Align the ∞ mark on focus ring to index. Set aperture to full aperture.
2. Readout values at either Wide or Tele side.
3. Remove the aperture ring.
4. If the value is above the standard, increase the thickness of the washer, otherwise decrease it.
5. Confirm that the value is within the standard range.

(Refer to page L8.)

Focal length (f)	Standard (mm)
35mm	+0.08 ~ +0.18
50mm	+0.08 ~ +0.20
70mm	+0.08 ~ +0.23
105mm	+0.08 ~ +0.23

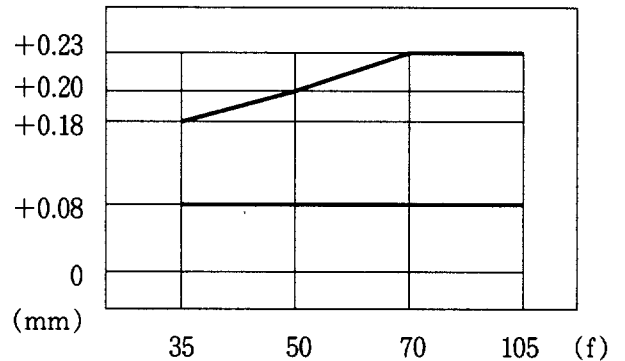

REAR COVER RING

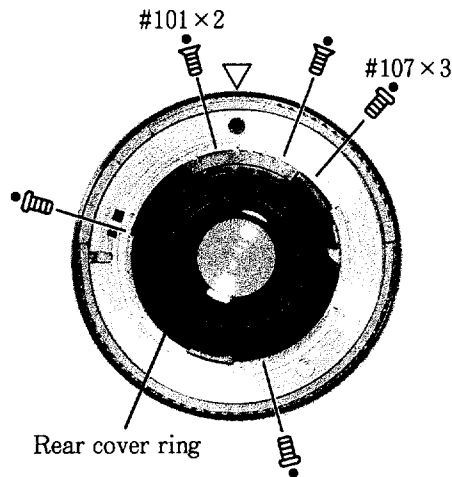

ATTACHING METER COUPLING SHOE

- (1) Take out aperture ring #28.
- (2) Make a hole (φ1.1) at the concave portion of aperture ring. Mount meter coupling shoe on the aperture ring and make another hole (φ1.1) based on the hole of meter coupling shoe.

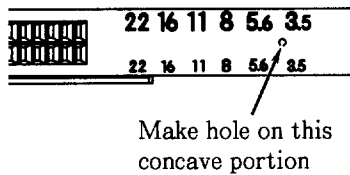

Meter coupling shoe	1K406 - 011	× 1
Screw	1K010 - 002 - 1	× 2
Change the length of screw from 2.5mm to 2.2mm.		

- (3) Mount meter coupling shoe.

Note : Exposure becomes underexposure by approximately 1/5 EV if the lens is mounted on a camera which is designed to set a full aperture F value with a meter coupling shoe.

- (4) Assembling.

INSPECTION OF ENCODER SIGNAL



※ Use an F90 (N90) camera body and checking & adjustment programs for F90/N90 to display encoder signal on the computer monitor when making an inspection.

Inspection method

- Start the checking & adjustment programs for F90/N90 and select “ E. Checking of AF lens communication ”. Make inspection according to instructions as shown on the display.
- Encoder signals should be as described in the table below when the zoom and distance scale are set to specified positions.

Zoom ring Distance scale position	f = 3 5 mm			f = 5 0 mm			f = 7 0 mm			f = 1 0 5 mm		
	Encoder signal											
	1	2	3	1	2	3	1	2	3	1	2	3
Most infinity position	5 2 h	D 8 h	D 1 h	5 2 h	D 8 h	F 2 h	5 2 h	D 8 h	F 9 h	5 2 h	D 8 h	5 A h
3 m										5 2 h	7 1 h	5 A h
2 m										5 2 h	D 9 h	5 A h
Most close distance position										5 2 h	7 B h	5 A h

- ◎ If encoder signal values are different from those shown in the table, following causes must be considered.
- Distance brush is mounted in the wrong position, distance brush or FPC is defective, encoder patterns on the FPC are contaminated, or the FPC is fixed in the wrong position.

作成承認印	配布許可印
	

AF Zoom-Nikkor 35-105mm f/3.5-4.5 D

PART LIST

修理部品表

Nikon | NIKON CORPORATION
Tokyo, Japan

© Copyright 1994
ALL RIGHTS RESERVED
無断転載を禁ず!!

部品表 Parts List

AF 35~105/3.5~4.5D

JAA74851-R.3370.A

部品番号 Part No.	補助番号 Ckt No.	名称 Name	1台分 個数 Pcs. Per Unit	部組品番号 Assembly	参照 図番 Fig. No.	販売区分 Term of Delivery	備考 Remarks	要求単位 Qty per order
*1K001-082	101	Screw	2		1 D3	○		10
*1K010-002-1	107	Screw	3		1 D4	○		10
*1K010-004	110	Screw	6		1-A2 1-D3	○		10
1K010-050	128	Screw	2		1 D4	○		10
*1K010-058	109	Screw	2		1 B4	○		10
*1K010-133	102	Screw	1		1 D4	○		10
1K110-419	120	両面テープ Tape	1		1 D1	×	TA-0003	1 roll
1K110-422	37	ゴムリング Rubber ring	1		1 C1	○		5
*1K115-966	89	ファインセーム Flock paper	1		1 A2	○		5
1K117-929	130	ポリエステルテープ Tape	1		1 D2	×	TA-0012	1 roll
*1K120-009	114	Screw	4		1 A2	○		10
*1K120-012	111	Screw	1		1 D4	○		10
*1K120-028	113	Screw	2		1 B1	○		10
*1K120-075	100	Screw	4		1 C4	○		10
*1K120-106	103	Screw	3		1 A4	○		10
*1K120-154-1	108	Screw	1		1 A3	○		10

部品表 Parts List

AF 35~105/3.5~4.5D

JAA74851-R.3370.A

部品番号 Part No.	補助番号 Ckt No.	名称 Name	1台分 個数 Pcs. Per Unit	部組品番号 Assembly	参照 図番 Fig. No.	販売区分 Term of Delivery	備考 Remarks	要求単位 Q'ty per order
*1K120-155	115	Screw	4		1 C1	○		10
*1K120-211	106	Screw	3		1 B4	○		10
*1K120-286	112	Screw	2		1 C4	○		10
*1K120-325-1 (1K120-325)	105	Screw	1		1 D4	○		10
*1K120-360	104	Screw	2		1 D4	○		10
*1K126-051	96	Screw	1		1 C2	○		10
*1K130-256	85	段付ネジ Screw	1		1 A3	○		10
*1K130-425-3 (1K130-425-1)	58	Screw	1		1 B4	○		10
*1K133-006	83	溝付ネジ Screw	1		1 D4	○		10
1K161-308	77	Washer t=4.4	1		1 A4	○		1
1K161-309	93	Washer t=0.05	0		1 B1	○		5
1K161-310		Washer t=0.06	0		1 B1	○		5
1K161-311		Washer t=0.07	0		1 B1	○		5
1K161-312		Washer t=0.08	0		1 B1	○		5
1K161-313		Washer t=0.09	0		1 B1	○		5
1K161-314		Washer t=0.1	0		1 B1	○		5
1K161-315		Washer t=0.2	0		1 B1	○		5
1K161-316		Washer t=0.3	0		1 B1	○		5

部品表 Parts List

AF 35~105/3.5~4.5D

JAA74851-R.3370.A

部品番号 Part No.	補助番号 Ckt No.	名称 Name	1台分 個数 Pcs. Per Unit	部組品番号 Assembly	参照 図番 Fig. No.	販売区分 Term of Delivery	備考 Remarks	要求単位 Qty per order
1K161-317	94	Washer t=0.05	0		1 C3	○		5
1K161-318		Washer t=0.06	0		1 C3	○		5
1K161-319		Washer t=0.07	0		1 C3	○		5
1K161-320		Washer t=0.08	0		1 C3	○		5
1K161-321		Washer t=0.09	0		1 C3	○		5
1K161-322		Washer t=0.1	0		1 C3	○		5
1K161-323		Washer t=0.2	0		1 C3	○		5
1K161-324	95	Washer t=0.8	0		1 B4	○		5
1K161-325		Washer t=0.05	0		1 B4	○		5
1K161-326		Washer t=0.06	0		1 B4	○		5
1K161-327		Washer t=0.07	0		1 B4	○		5
1K161-328		Washer t=0.08	0		1 B4	○		5
1K161-329		Washer t=0.09	0		1 B4	○		5
1K161-330		Washer t=0.1	0		1 B4	○		5
1K161-331		Washer t=0.2	0		1 B4	○		5
1K161-332		Washer t=0.3	0		1 B4	○		5
1K161-333		Washer t=0.5	0		1 B4	○		5

部品表 Parts List

AF 35~105/3.5~4.5D

JAA74851-R.3370.A

部品番号 Part No.	補助番号 Ckt No.	名称 Name	1台分 個数 Pcs. Per Unit	部組品番号 Assembly	参照 図番 Fig. No.	販売区分 Term of Delivery	備考 Remarks	要求単位 Qty per order
1K161-334	97	Washer t=0.3	1		1 A1	○		5
*1K208-097	74	EEロックボタン EE lock button	1		1 B4	○		5
*1K225-077-1	86	Spring	1		1 A3	○		5
*1K225-152-1 (1K225-152)	84	Spring	1		1 D4	○		5
*1K240-563	75	板バネ Leaf spring	1		1 B4	○		5
*1K240-587-1	36	板バネ t=0.2 Leaf spring	0-1		1 B3	○		5
*1K240-715-1		板バネ t=0.18 Leaf spring	0-1		1 B3	○		5
*1K240-970		板バネ Leaf spring	0-1		1 B3	○		5
1K240-923	76	フォーカスエンコーダブラシ Focus encoder brush	1		1 C2	○		5
1K240-956	127	板バネ Leaf spring	1		1 D3	○		5
1K260-680	25	ギア付丸環 Ring	1		1 D3	○		1
1K260-681	54	カップリングギア Coupring gear	1		1 B4	○		1
1K277-166	55	Gear	1		1 D2	○		1
*1K300-086-1 (1K300-086)	21	平面カム Cam	1		1 B4	○		1
1K340-237	56	ブッシュ Bush	1		1 D2	○		1
1K400-352	38	フィルター取付環 Filter ring	1		1 A1	○		1
*1K404-119	30	バヨネット Bayonet mount	1		1 D4	○		1

部品表 Parts List

AF 35~105/3. 5~4. 5D

JAA74851-R. 3370. A

部品番号 Part No.	補助番号 Ckt No.	名称 Name	1台分 個数 Pcs. Per Unit	部組品番号 Assembly	参照 図番 Fig. No.	販売区分 Term of Delivery	備考 Remarks	要求単位 Qty per order
1K437-208	22	キー Key	1		1 C1	○		5
1K475-517	26	距離環 Focus ring	1		1 D1	○		1
1K475-518	27	ズーム目盛環 Zoom index ring	1		1 A4	○		1
1K485-216	29	丸環 Ring	1		1 B4	○		1
1K485-217	51	指標環 Index ring	1		1 A2	○		1
*1K521-062	57	押さえ環 Retaining ring	1		1 C4	○		1
1K521-215	41	G 1. G 2 押さえ環 G1.G2 retaining ring	1		1 B1	○		1
1K521-216	43	G 4 - G 6 押さえ環 G4-G6 retaining ring	1		1 B2	○		1
1K521-217	45	G 9. G 9 押さえ環 G9.G10 retaining ring	1		1 C3	○		1
1K521-218	47	G 1 2. G 1 3 押さえ環 G12.G13 retaining ring	1		1 D3	○		1
1K572-169	33	絞り作動板 Blade actuating plate	1		1 B3	○		1
1K574-157	34	羽根基板 Blade mounting plate	1		1 A3	○		1
1K601-278	62	地板 Plate	1		1 D2	○		5
1K601-279	63	地板 Plate	1		1 C2	○		5
1K601-281	118	平板 Plate	1		1 C4	○		5
1K601-282	119	Washer	1		1 B4	○		5

部組品表 Assembly List

AF 35~105/3.5~4.5D

JAA74851-R.3370.A

部組番号 Part No.	補助番号 Ckt No.	名称 Name	1台分 個数 Pcs. Per Unit	構成部品番号 Constituent Parts	参照 図番 Fig. No.	備考 Remarks	要求単位 Q'ty per order
1B002-085	B5	ヘリコイド環組 Helicoid unit	1	1K302-075 1K302-074 1K307-028 1K641-276 1K630-855 1K630-856	1 B2		1
1B060-558	B9	AF接点組 AF contact unit	1	1K681-624 1K681-625 1K240-469-1x5 1S015-075 1K116-398x2 1K117-078 1K110-314	1 D2		1
1B100-674	B1	G3レンズ室組 G3 lens housing unit	1	1G154-124 1K500-877	1 B1		1
1B100-675	B2	G7レンズ室組 G7 lens housing unit	1	1G152-075 1K500-878	1 B2		1
1B100-676	B3	G8レンズ室組 G8 lens housing unit	1	1G107-078 1K500-879	1 B3		1
1B100-677	B4	G11レンズ室組 G11 lens housing unit	1	1G146-024 1K500-880	1 C3		1
1B240-110	B7	ズームエンコーダブラシ組 Zoom encoder brush unit	1	1K240-924 1K681-662	1 D3		1
1B570-107	B6	絞り羽根 Diaphragm blade	7	1K570-131 1K370-004-2x2	1 A3		10
1G016-074	G1.2	G1. G2レンズ G1.G2 Lens element	1	1G254-096 1G112-039	1 B1		1
1G022-032	G5.6	G5. G6レンズ G5.G6 Lens element	1	1G202-050 1G147-046	1 B2		1
1G027-074	G9.10	G9. G10レンズ G9.G10 Lens element	1	1G103-039 1G202-051	1 B3		1

部組品表 Assembly List

AF 35~105/3. 5~4. 5D

JAA74851-R. 3370. A

部組番号 Part No.	補助番号 Ckt No.	名 称 Name	1台分 個 数 Pcs. Per Unit	構成部品番号 Constituent Parts	参照 図番 Fig. No	備 考 Remarks	要求単位 Q'ty per order		
1B999-755	B20	ガイド環 Guide ring	0-2	1K130-537 1K117-709	1 B2		10		
1B999-756		ガイド環 Guide ring						φ3.5	φ3.49
1B999-757		ガイド環 Guide ring						φ3.48	φ3.51
1B999-758		ガイド環 Guide ring						φ3.51	φ3.51
1B999-759	B21	ガイド環 Guide ring	1	1K130-536 1K117-705 1K117-709	1 B2		10		
1B999-760		ガイド環 Guide ring						φ3.5	φ3.49
1B999-761		ガイド環 Guide ring						φ3.48	φ3.48
1B999-762		ガイド環 Guide ring						φ3.51	φ3.51
1B999-763	B26	ガイド環 Guide ring	0-6	1K130-534 1K117-701	1-A3 1-B3 1-C3		10		
1B999-764		ガイド環 Guide ring						φ4.5	φ4.49
1B999-765		ガイド環 Guide ring						φ4.48	φ4.48
1B999-766		ガイド環 Guide ring						φ4.51	φ4.51
1B999-767	B29	ガイド環 Guide ring	0-2	1K130-535 1K116-936	1 C2		10		
1B999-768		ガイド環 Guide ring						φ4.5 +0.02 +0.01	φ4.5 +0.01 0
1B999-769		ガイド環 Guide ring						φ4.5 0 -0.01	φ4.5 -0.01 -0.01
1B999-770		ガイド環 Guide ring						φ4.5 -0.01 -0.02	φ4.5 -0.02 -0.02
1B999-771		ガイド環 Guide ring						φ4.5 -0.02 -0.03	φ4.5 -0.03 -0.03