

**Nikon** **F3** **F3** high-eyepoint

**Nikon**



## **The Nikon F3. Step beyond the ordinary.**

Born into a tradition of rugged dependability.

Endowed with a breathtakingly handsome camera body which handles even better than it looks.

Inheriting the most comprehensive group of lenses and accessories ever assembled in photography.

Then selected by NASA for use in the Space Shuttle Program\*, the most ambitious technological venture of all time.

With a heritage like this, is it any wonder that the Nikon F3 is the overwhelming choice of professional photographers around the world? More than just a camera, the F3 is the realization of Nikon's dream of designing the ideal picture-taking machine.

For truly out-of-the-ordinary pictures, create them with the extraordinary Nikon F3... perhaps the finest camera ever conceived.

\* A special version of the Nikon F3, modified to meet the unique environmental conditions encountered in space flight, was selected by the United States National Aeronautics and Space Administration.







**Two  
cam  
t  
choos**

## **Nikon F3**

The standard model. Precise frame coverage shows virtually 100% of the image that will appear on film. Easy-to-see liquid crystal display (LCD) exposure readout outside the frame. Aperture-priority automatic and manual exposure control from 1/2000sec. to 8 full seconds. Complete interchangeability of finders, focusing screens and camera backs. Plus the most complete line of accessories found anywhere. Truly a camera to match your imagination.

great  
eras  
o  
e from.



## **Nikon F3** high-eyepoint

The same as the regular F3, only the viewfinder is different. This model is designed especially for people who wear glasses, like to shoot sports action, or are used to wearing sunglasses. With a larger viewfinder eyepiece, you can see the entire frame, including all exposure information, at a glance...with your eye up to 25mm (approx. one inch) away. All this with only a minuscule increase in size and weight. Now that's convenience.



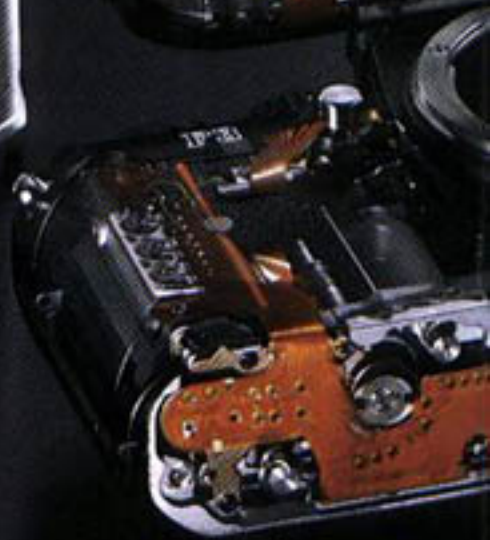
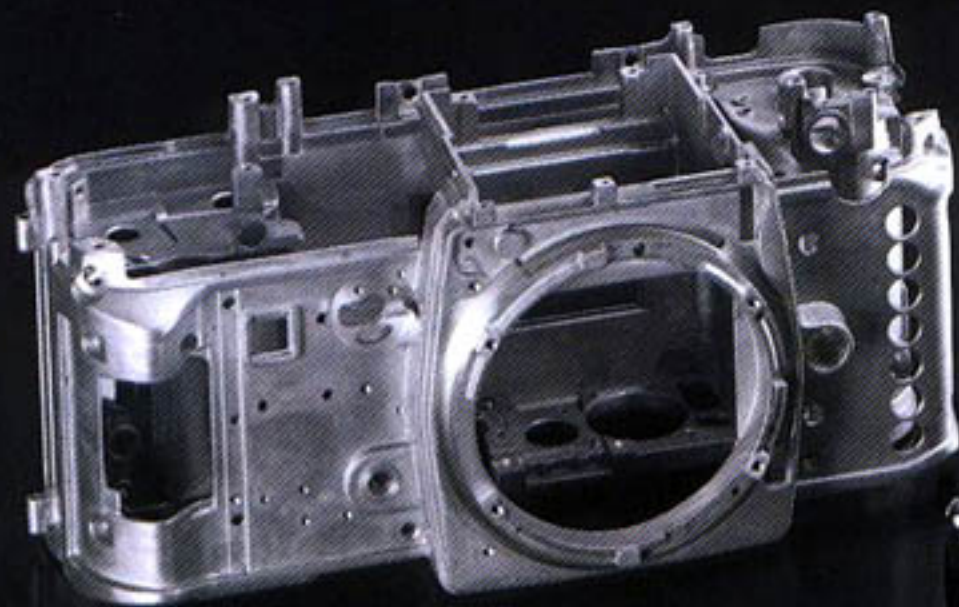

## A design unlike any other.

Reliable under the most demanding circumstances. Durable enough to stand up to the rigors of daily professional use. Underneath that handsome exterior, the Nikon F3 is built Nikon-tough. It features:

### **Solid Die-Cast Body**

To make the F3 sturdy but light, the "backbone" of the camera consists of a two-piece body casting of copper silumin aluminum alloy, a metal selected for its incredible strength and resistance to corrosion. For maximum rigidity, the thickness of the body walls is never less than

1.4 mm, while the portion that attaches to the lens mount is a robust 2 mm.

### **State-of-the-Art Microelectronics**

Wrapped around the backbone is the "central nervous system" of the Nikon F3. Data processing is handled by a staggering array of microelectronic components, including six IC's and LSI's, a Nikon-designed functional resistance element (FRE), one silicon photodiode (SPD), a quartz oscillator, plus the LCD. Yet despite this complexity, all electronic components have been integrated onto a single flexible

printed circuit (FPC) board to provide the correct exposure in any picture-taking situation... with computer-like speed and reliability.

And remember, the Nikon F3 was the first—and is still the *only*—camera to feature digital LCD exposure readout in the viewfinder. With unobtrusive black-on-white numerals, LCD is never distracting, plus it's easy to view for long periods. But even more important, LCD requires just 1/10,000th the amount of power needed by LED's, making the F3 one of the most energy-efficient cameras on the market today.

### **Sophisticated Winding Mechanism**

Film winding is silky-smooth and effortless, thanks to the liberal use of ball bearings and a brand new winding mechanism employed for the first time. In the F3, a special connecting shaft is employed as the center of winding power transmission. This allows the gear trains between the axes of the shutter drum, film sprocket, and takeup spool to be shorter and simpler than those of ordinary mechanisms, thus reducing winding torque.



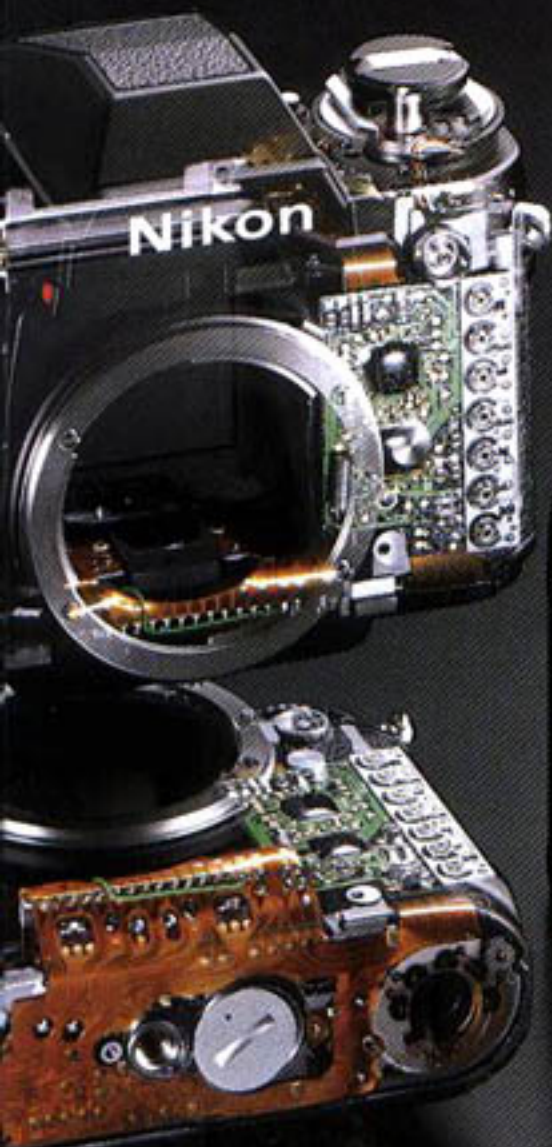

### **Nikon-Designed Shutter**

The F3 features a focal-plane shutter designed and built exclusively by Nikon. In Nikon's design, the first and second curtains are both wound around the main drum. The result is simplified construction and more efficient operation for years of trouble-free performance. It also features ultra-thin titanium shutter curtains which are durable, yet light, providing up to 150,000 shutter firings.

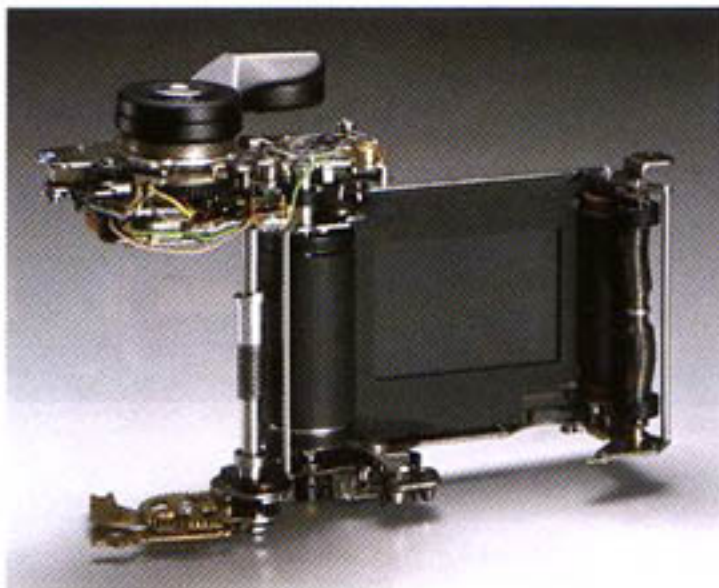



# Control light itself.

From glaring sun in the desert to the dimmest candlelight—automatically or manually—the Nikon F3 puts you in total control of any lighting situation.



## Automatic Exposure Control

Set the lens aperture. Then lock the shutter speed dial at A and fire away. While you're focusing and composing, the Nikon F3 is setting the right shutter speed... automatically from 1/2000 sec. down to 8 full seconds. To keep you informed, a digital LCD readout of the shutter speed appears above and outside the picture area for easy viewing. For simplicity, discrete shutter speeds are shown (e.g., 1/250 sec.) even though the automatically selected speed might be actually 1/287 sec. Moreover, Nikon's ADR (aperture direct readout) window clearly shows the lens aperture in use. But that's not all. To give you the final say over the automatic exposure setting, the F3 features both an exposure memory lock and exposure compensation dial.

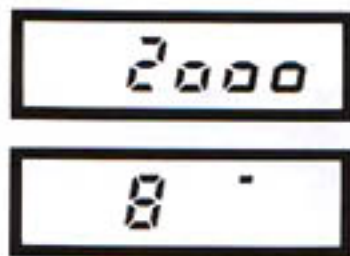

Shutter speed indications of 1/2000 sec. and 8 sec.



## Exposure Memory Lock

For backlit subjects or those that contrast sharply with the background, you can use this control to get the correct exposure on auto. All you have to do is center the main subject in the viewfinder. Then depress the memory lock button and, while holding it in, recompose the picture and shoot.

## Exposure Compensation Dial

For shooting predominantly light- or dark-toned scenes or creating intentional over- or underexposure on auto, this dial has settings in one-third increments from +2 to -2 EV. It also can be used to bracket your shots without having to set the shutter speed or aperture manually.

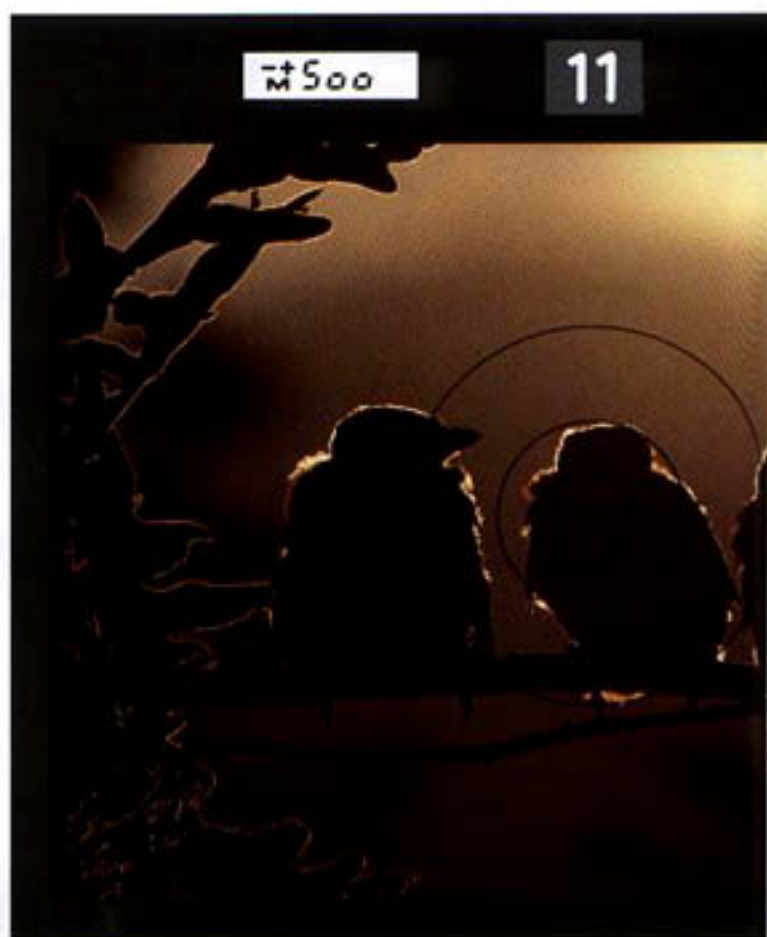

## Built-into-the-Body Metering System

All electronic components are built into the camera body, so exposure control is possible with every interchangeable viewfinder and focusing screen. By utilizing an ingenious two-piece reflex mirror, the Nikon F3 meters the light through the lens and *on optical axis* for total accuracy. In the center of the main mirror are no less than 50,000 unsilvered "pinholes," allowing precisely 8% of the light to pass through. This light is then reflected off a "piggyback" secondary mirror down to the fast-reacting SPD light sensor located at the bottom of the mirror box and facing toward the rear.



Main mirror with pinhole area

In Nikon's system, the pinhole area has absolutely no effect on the brightness of the viewfinder image. Also its highly center-weighted pattern—80% sensitivity is concentrated into the 12 mm-diameter spot in the center of the viewfinder frame—lets you know exactly what the camera is metering.





J.L.G. Grande

- ① Pentaprism
- ② ADR window
- ③ LCD
- ④ Aperture scale
- ⑤ Eyepiece
- ⑥ Focusing screen
- ⑦ Main reflex mirror
- ⑧ Film
- ⑨ Secondary mirror
- ⑩ Condenser lenses
- ⑪ SPD light sensor

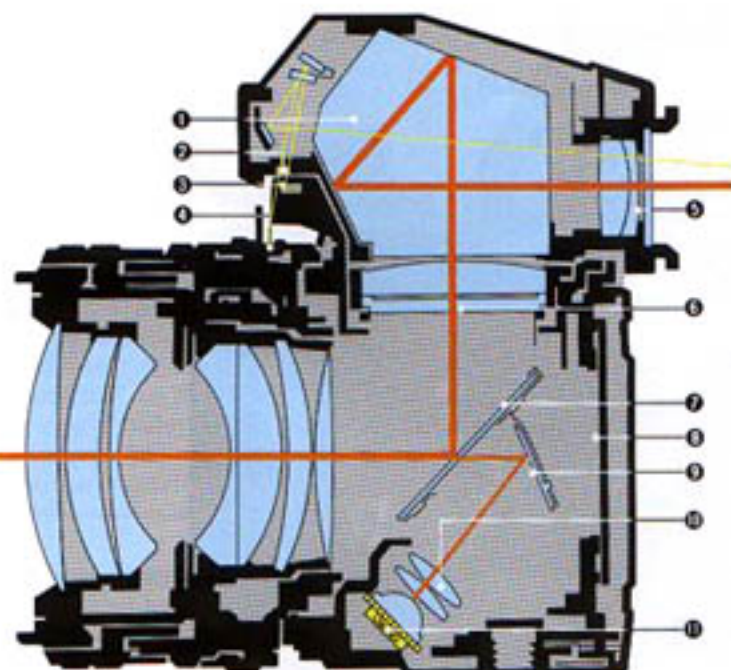

## Manual Exposure Control



### Usable Shutter Speeds

In the manual mode, you can use any of 15 different shutter speeds from 1/2000 to 8 sec. The shutter speed dial also incorporates an X (1/80 sec.) setting for use with electronic flash units, plus B (bulb) and T (time) for making time exposures.

### Mechanical Usage

In the event of battery failure, the Nikon F3 can still be used to take pictures at approx. 1/60 sec. by tripping the shutter with the special backup mechanical release lever conveniently located on the front of the camera body. For making lengthy time exposures without battery drain, you can set the shutter speed dial to T and trip the shutter using the same lever.

The Nikon F3 brings the unprecedented accuracy of quartz to its manual shutter speed range. All speeds are timed with a quartz oscillator which remains stable despite changes or fluctuations in temperature and voltage. Combine this with Nikon's ultra-reliable shutter and you have timing of the highest order.

### Exposure Information on Manual

As soon as the shutter speed dial is set manually, an M appears just to the left of the digital shutter speed in the LCD.

	<b>5.6</b>
+ indicates overexposure by 1/4 stop or more	
	<b>5.6</b>
- indicates underexposure by the same amount	
	<b>5.6</b>
+ indicates correct exposure	



**Self-Timer**

To get yourself into the picture, the electronic self-timer provides a delay of exactly 10 seconds (via quartz timing). A bright red self-timer LED blinks to indicate operation, then speeds up for the last two seconds to indicate the picture will soon be taken.

**Depth-of-Field Preview Button**

When pushed in, it gives you a visual indication of which parts of the scene from near to far will be in sharp focus.

**Viewfinder Illuminator**

For seeing the exposure information in dim light or at night, a tiny "grain-of-wheat" bulb built into the camera body illuminates both the LCD and ADR readouts when this small red button is pushed.

**Sync Terminal**

Threaded for positive connection with Nikon sync cords for off-camera flash.

**Lens Release Button**

For extra-fast handling when changing lenses, this button lets you remove the lens in just 1/6 of a turn clockwise.

**Accessory Shoe**

Allows direct mounting of the Nikon Speedlight SB-16A, SB-17 or the control cord for other Speedlights. Three electrical contacts provide totally automatic through-the-lens flash exposure control.

**Mirror Lockup Lever**

To reduce vibration to the absolute minimum when taking close-ups, doing document copying, or using supertelephoto lenses, the mirror can be locked in the "up" position.

# It handles like a dream.

Stylishly sculpted by the world-renowned industrial designer, Giorgetto Giugiaro, the Nikon F3 is not only beautiful to look at but wonderfully easy to handle. Every single control necessary for fine picture taking is right where you want it.





### Shutter Speed Dial ①

19 settings to choose from. Automatically locked at both the A and X settings to prevent mistakes.

### Film Advance Lever ②

Specially contoured to fit the thumb perfectly, this lever advances the film and cocks the shutter in one short 140° stroke or a series of strokes. Has a 30° stand-off angle.

### Shutter Release Button ③

Provides smooth electromagnetic shutter release. The button also functions as a meter-on switch when depressed halfway. After finger pressure is removed, the

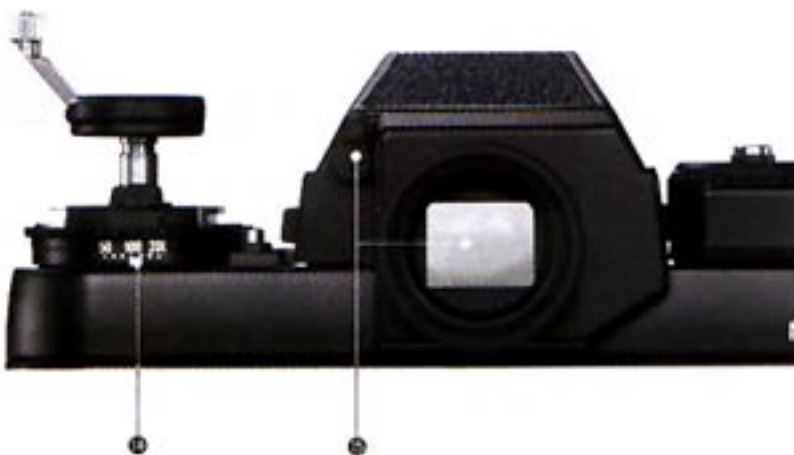

### ASA/ISO Film Speed Dial ④

With speeds all the way from ASA/ISO 12 to 6400 to choose from, you can shoot at normal film speeds or "push" your high-speed films as much as you want. When used in conjunction with the exposure compensation dial, the ASA/ISO range increases to 6 to 12800.

### Eyepiece Shutter ⑤

Blocks out extraneous light from the viewfinder when the F3 is operated with the self-timer or by remote control.



meter stays on (with LCD indication) for 16 seconds, then turns itself off automatically to conserve battery power. Threaded in its center for use with any standard cable release, such as the Nikon AR-3.

### Frame Counter ⑧

Graduated from two frames below 0 up to 40. Self-resetting as soon as the camera back is opened. Does not advance during multiple-exposure operation.

### Multiple Exposure Lever ⑥

Creative multiple exposures are so easy with the F3. When this lever is pushed out to the ready position, you can cock the shutter without advancing the film. It springs back to the rest position at the end of the winding stroke. For motor-driven multiple exposure, you can hold it in the ready position.

### Release Lock ⑦

Locks the shutter release button to prevent accidental release and battery drain.

# More than a little black box.

Nikon invented the concept of modular construction way back in 1959 with the legendary Nikon F. The idea was simple: make the camera body a basic building block to which everything else could be attached. This concept allowed the same camera body to handle a multitude of photographic situations simply by changing the accessory. Now the Nikon F3—the third camera in Nikon's highly acclaimed professional series—takes modular construction one step further. The camera body is the electronic control center for all camera functions. So, regardless of the accessory in use, you still have complete exposure control.





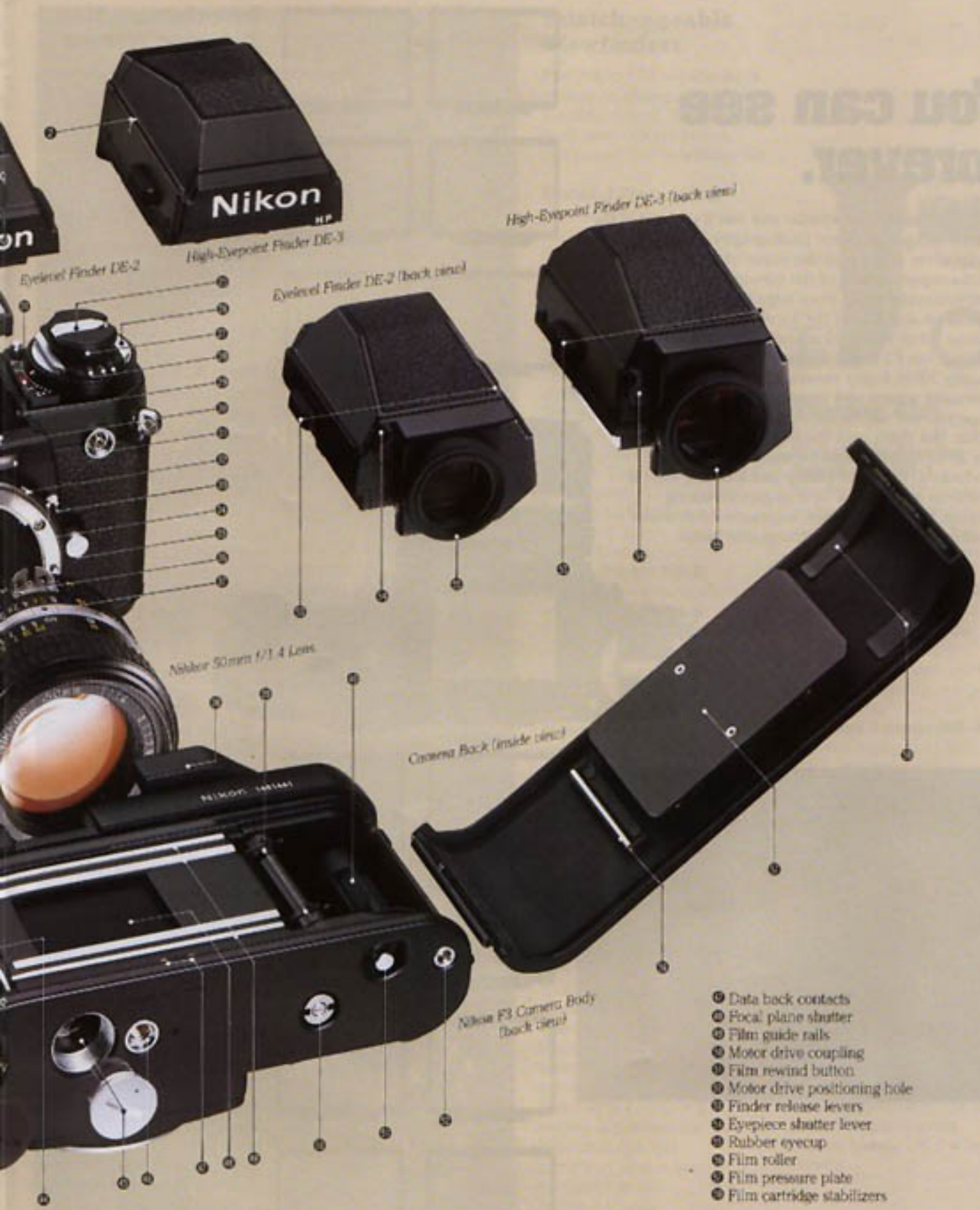

- ① Data back contacts
- ② Focal plane shutter
- ③ Film guide rails
- ④ Motor drive coupling
- ⑤ Film rewind button
- ⑥ Motor drive positioning hole
- ⑦ Finder release levers
- ⑧ Eyepiece shutter lever
- ⑨ Rubber eyecup
- ⑩ Film roller
- ⑪ Film pressure plate
- ⑫ Film cartridge stabilizers



# You can see forever.

Look into the F3's viewfinder and you'll see one of the clearest images in 35mm photography. Thanks to a special silver coating on the inside of the pentaprism and the superb design of the viewing optics, the image is exceptionally sharp from edge to edge and it's easy to focus on any part of the focusing screen. And because Nikon's camera assembly techniques are so exacting, the F3 is still the only camera that offers virtually 100% frame coverage with every combination of focusing screen and viewfinder. This insures that the image you see will be the same as the one recorded on film. But that's only the beginning. With no less than 22 interchangeable focusing screens and 5 viewfinders, the same clarity and focusing ease is possible in any type of light or picture-taking situation. For convenience, exposure information is visible with every interchangeable finder.

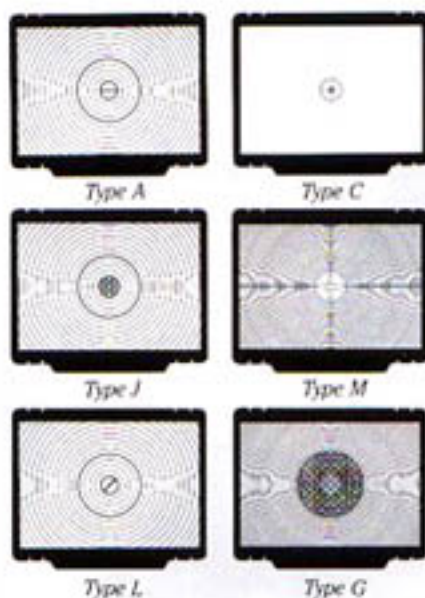

Type K

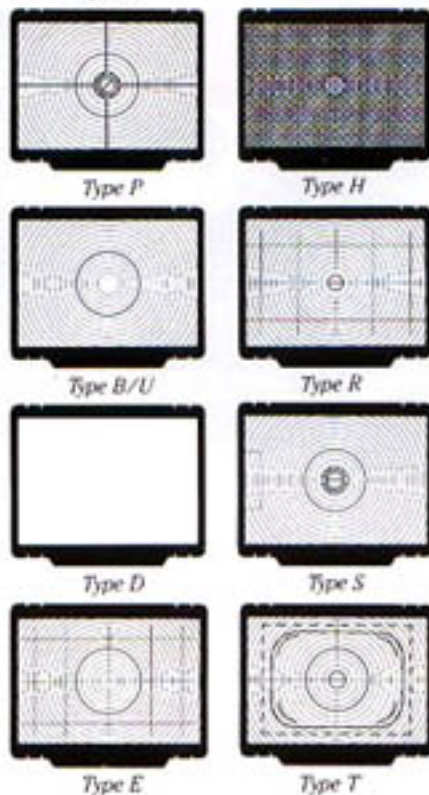

## Interchangeable Focusing Screens

All focusing screens are user-interchangeable without tweezers. To install or remove, simply grasp the back of the screen by its protruding lip and drop-in or lift it out.

### Type K

Standard equipment on both the Nikon F3 and F3 High-Eyepoint cameras. Features a matte Fresnel field with split-image rangefinder and microprism collar.

### Types A, J, L, P

Having either a split-image rangefinder and/or a microprism, these screens are designed for general photography.

### Types B, D, U

Offer unobstructed viewing and easy focusing on their overall matte surfaces. Type B for general use. Types D and U designed especially for telephoto lenses.

### Type E

With its grid pattern, it is ideal for architectural photography with PC-Nikkor lenses.

### Types C, M

Used with the DW-4 Finder for taking high-magnification close-ups or for astrophotography.

### Type G, H

Rapid focusing on the central or overall microprisms. Exceptionally bright image because matte surface is not used. Perfect for shooting in dim light or for fast-moving subjects. Each type available in four models to match various focal lengths.

### Type R

Special split-image rangefinder with grid pattern. Excellent with lenses having maximum apertures of  $f/3.5$  to  $f/5.6$ , especially the PC-Nikkor 28mm  $f/3.5$ .

### Type S

Same as Type K except provides area on the left side of frame for data imprinting when used with 250-exp. Data Back MF-17.

### Type T

Indispensable when preparing slides for TV broadcasts.





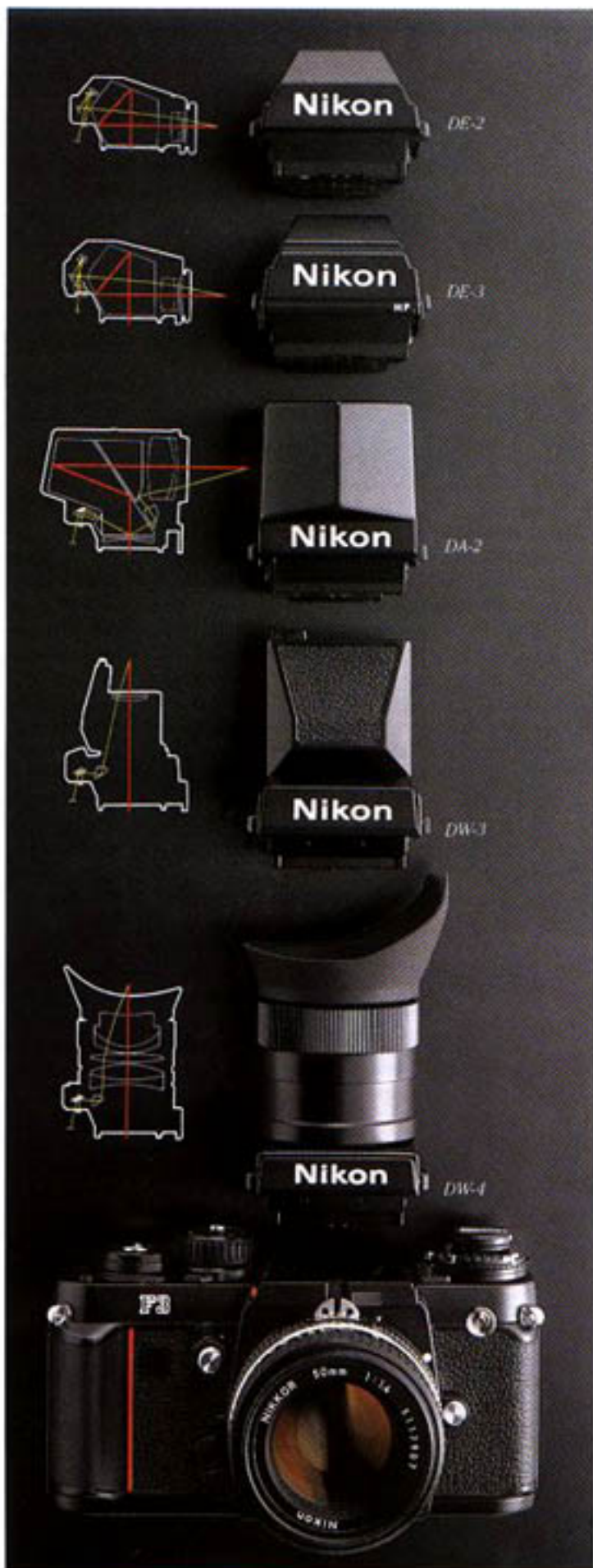

## Interchangeable Viewfinders

The Nikon F3's viewfinder is as easy to change as the focusing screen. By pulling back both release levers, you can lift the viewfinder out.

### Eyelevel Finder DE-2

Standard equipment on the regular Nikon F3, 0.8X magnification with the 50mm lens at infinity. Eyepiece shutter incorporated.

### High-Eyepoint Finder DE-3

Standard equipment on the Nikon F3 High-Eyepoint camera. Also available as an accessory for the regular F3. The entire frame, including exposure information, is visible with the eye up to 25 mm (approx. 1 inch) away from the eyepiece. 0.75X magnification with the 50mm lens focused at infinity. Eyepiece shutter built in.

### Action Finder DA-2

Perfect for situations where normal viewing is difficult or impossible, such as when wearing a helmet, goggles or with the camera encased in a special housing for underwater photography.

### Waist-Level Finder DW-3

For use when the F3 is used at a low angle or on a copy-stand. Fold-up type viewing hood provided. The built-in flip-up magnifier provides a 5X magnification of the center of the image for accurate focusing.

### 6X High-Magnification Finder DW-4

For critical high-magnification close-up work and photomicrography. Its sophisticated optical system provides a clear, sharp, undistorted view of the entire image at full 6X magnification. Fitted with a -5 to +3 diopter adjustment for individual eyesight correction, plus rubber eyepiece cup and eyepiece shutter.



## Viewing Aids

### Right-Angle Viewing Attachment DR-3

Provides an upright and unreversed image with right-angle viewing. Individual eyesight adjustment possible. Excellent for copy work.

### Eyepiece Magnifier DG-2

Gives 2X magnification of the central portion of the finder image. Eyesight adjustment provided. Useful for critical focusing in close-up photography.

### Eyepiece Adapter DK-1

Lets you attach the DR-3, DG-2, or rubber eyecup to the DE-3 finder's eyepiece.

### Eyepiece correction lenses

Allow nearsighted and farsighted photographers to view and focus accurately with the regular F3 without having to wear their glasses. Nine lenses are available, from +3 to -5 diopters. F3 High-Eyepoint has four exclusive eyepiece correction lenses, from +2 to -2.

### Rubber Eyecups DK-2/DK-3

Increase viewing comfort and prevents stray light from entering viewfinder. The DK-2 is for F3 High-Eyepoint camera and the DK-3 is for F3 camera.



# Non-stop creativity.

## Motor Drive MD-4

Nikon continues to write and rewrite the history of motor drives. In 1957, Nikon created the very first battery-powered motor drive. And now with the MD-4, we have the fastest regular-production motor drive on the market today. At 6 frames per second on continuous, it lets you create action-packed sequences or capture the "decisive moment" in a single frame. Combine this with powered film rewinding—in a short 4.5 sec.—and you have a motor drive that never lets you miss what's happening.\*

The MD-4 is also handsomely sculpted to be a logical

extension of the F3's classic lines and is built tough like the camera itself. It features an all-metal die-cast body, sophisticated microelectronics utilizing one IC, and ball bearings in the winding mechanism. Because of the exceptionally low winding torque of the camera and motor drive, up to 140 rolls of 36-exp. film can be shot on one set of eight AA-type alkaline batteries. Moreover, as soon as the MD-4 is attached, all camera functions are powered by the motor drive. So, by using the NiCd Battery Unit, which is more resistant to cold weather, you can take pictures down to -20°C.

One "accessory" you'll never want to be without, the MD-4 provides non-stop excitement at the push of a button.



## Easy to Use

All controls are where you want them. At the top is the trigger button (which operates exactly like the camera's shutter button to turn on the motor), plus the mode selector with three settings: C (continuous), S (single frame), and L (lock). On the back rewind slides with safety lock for automatic film rewinding.

## Firing Rate Converter MK-1

Attaches to the bottom of the MD-4 Motor Drive to provide three firing rates of 1, 2 and 3 frames per second. Also contains its own trigger button for ease in vertical-format shooting.



## Specifications

<b>Max. firing rate</b> (frames per second)	With 8 AA-perlight alkaline batteries	Normal	With mirror up
	With NiCd Battery Unit MN-2	3.8	1
	With AC/DC Converter MA-1	5.5	6
<b>Number of 36-exp. rolls</b>	With alkaline batteries	5	5.5
	With MN-2	Guaranteed firing rate	Slower rates
	With MA-1	60	110
<b>Usable shutter speeds</b>	With alkaline batteries	60	20
	With MN-2	Unlimited	Unlimited
	With MA-1	Unlimited	Unlimited
<b>Dimensions (W x H x D)</b>	8 sec. to 1/2000 sec. (including X-TTL/50 sec. 1		
<b>Weight (without batteries)</b>	146.5 mm x 115 mm x 77 mm		
	180g		

\*6 frames per second is possible at 1/125 sec. and above with the mirror locked in the "up" position when using the MN-2 NiCd Battery Unit; automatic rewinding in 4.5 sec. possible with the MN-2.



## Camera Backs

- ① External power terminal
- ② Remote terminal
- ③ Magazine back terminal
- ④ Automatic film rewind fork
- ⑤ Attachment wheel
- ⑥ Battery check button
- ⑦ LED indicators
- ⑧ Auto rewind-stop terminals
- ⑨ Rewind slide 2
- ⑩ Frame counter
- ⑪ Counter setting dial
- ⑫ Rewind slide 1 with lock button
- ⑬ Trigger button
- ⑭ S-C mode selector



MF-4



MF-6B

### 250-Exposure Film Back MF-4

Provides unlimited fire power for industrial or scientific applications. Has its own trigger button for handling

ease. Used with two 250-Exposure Magazines MZ-1 for loading up to 10 m of bulk film.

### Camera Back MF-6B

Automatically stops the film from being rewound completely back into the cartridge during auto-rewind.

### 250-Exposure Data Back MF-17

Used in combination with the MF-4. Allows imprinting of data (either year/month/day, hour/minute/second, or hand-written memo) on the film. Compatible with every F3 camera. Requires Type S screen.

## Power Sources

MN-2 MH-2



MA-4



### NiCd Battery Unit MN-2 and Charger MH-2

Powers the motor drive up to 6 frames per second. 3.5-hour recharging time; may be recharged approximately 100 times.

### AC/DC Converter MA-4

Supplies the motor drive with a stable DC current for extended studio use. Used with the MC-11 External Power Cord.

## Remote Control Accessories

MC-12A



### Remote Cord with Button Release MC-12A

Allows you to operate the camera up to 3 meters away.

### Modulite Remote Control Set ML-1

Controls up to two F3's by a modulated burst of light. Compact and easy to use up to 60 meters away.



MT-2

ML-1



MW-2

### Intervalometer MT-2

For unmanned time-lapse photography or work sampling. Quartz-controlled MT-2 provides 2 or 16 sec. delay in shutter release, allowing time for flash recycling. Can also be used with other remote control devices like the MW-1.

### Radio Control Set MW-2

Provides remote control up to 0.7 km away. Three cameras can be controlled simultaneously.

## Accessories for Easy Operation

MR-3



Pistol Grip Model 2

AH-3



MC-3A

### Terminal Release MR-3

Allows use of the AR-3 Cable Release or the AR-7 Double Cable Release.

### Pistol Grip Model 2 and Connecting Cord MC-3A

Provides a convenient handle when using long telephoto lenses.

### Tripod Adapter AH-3

Moves the tripod socket to the middle of the MD-4's base.

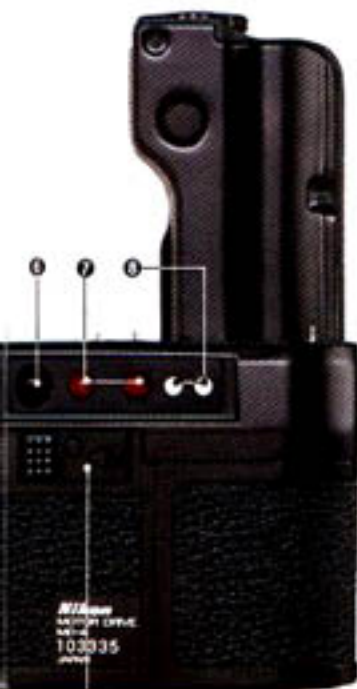
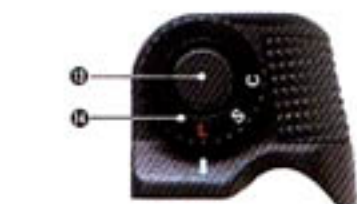

⑩

# Portable sunshine.

Automatic through-the-lens control of the flash exposure—just think of the possibilities. You can bounce the light off the ceiling or walls, even shoot through filters at a wide choice of apertures without worrying about the exposure.

Speedlights SB-11, 14, 16A and 17 let you meter the flash exposure through the lens and directly off the film plane for perfect exposure every time. All you have to do is set an aperture on the lens. Then turn the flash on and wait for the readylight to come on before taking the picture. It's so easy. With the F3 on auto, the correct synchronization speed (1/80 sec.) is automatically set, so it's impossible to make a mistake. Or for balancing the flash illumination to the existing light, you can shoot on manual at all speeds of 1/60 sec. and below. Moreover, the LED ready-light inside the F3's viewfinder not only lights up as soon as the flash is ready to fire, but even blinks after the shot if the light output was insufficient.

For close-ups, Nikon also offers Macro Speedlight SB-21A. And with such an outstanding array of electronic flash equip-



ment to rely on, the Nikon F3 will never leave you in the dark.



## Speedlight SB-14

Compact head-and-handle electronic flash unit with a guide number of 32 (ASA/ISO 100 and meters). Flash head tilts back 120° and rotates 120° to the right or left for total bounce control. Used with separate Battery Pack SD-7 which accepts six C-type alkaline batteries. Comes with Sensor Unit SU-2 for non-TTL automatic operation. Automatic through-the-lens operation is possible with the optional TTL Sensor Cord SC-12.



## Speedlight SB-17

Compact, versatile direct-mounting unit provides control of bounce flash with rotating flash head and tilting flashtube module. 25 guide number and synchronizes with motor drive (3.8 frames per sec.) for four shots.



### Speedlight SB-16A

Most versatile Nikon flash with powerful guide number of 32. Mounts directly to camera and features two flash heads for more natural bounce-flash portraits: main head tilts and rotates while secondary faces straight ahead to provide catchlight in subject's eyes. Main head also zooms to match angle of coverage for 28, 35, 50, and 85 mm lenses (with Wide-Flash Adapter, 24 mm also usable). Special MD (motor drive) setting let you shoot four consecutive frames at 4 frames per second. First Nikon flash with interchangeable mounting feet, so usable with other Nikon cameras having regular ISO accessory shoe.



### Macro Speedlight SB-21A

Enables you to use TTL automatic exposure for shadowless wraparound macro photography. Two built-in flash modules provide full-surround illumination, so you can flawlessly capture the details of the world in miniature, without

distracting shadows. Convenient focus illuminator ensures pinpoint focus adjustment. And a wide illumination panel lets you shoot flash-to-subject distances closer than 40 mm. Can be used with external power source (AC or DC).



### Speedlight SB-11

Nikon's most powerful electronic flash unit. Guide number of 36. Features a 120° tilting flash head for bounce flash and accepts batteries in its grip for convenient one-piece operation. Comes with the SU-2. Automatic TTL control possible with the SC-12.



### Flash Unit Coupler AS-4

Converts F3's accessory shoe to standard ISO-type hot shoe for attachment of Speedlights such as SB-20 or SB-22.



### Flash Unit Coupler AS-7

This coupler allows film change without removing the flash unit. Features both F3 and ISO-types accessory shoe for direct mounting of all Nikon Speedlights, including the SB-20 and SB-22.



Specifications	SB-11 (w/SC-12)	SB-14 (w/SC-12)	SB-16A	SB-17
Usable <i>f</i> /stop range	1/2 ~ 1/22	1/2 ~ 1/22	1/2 ~ 1/22	1/2 ~ 1/22
TTL auto shooting range* (at ASA/ISO 100)	1 ~ 18m	0.6 ~ 16m	0.6 ~ 21m	0.6 ~ 12m
Power source	8 AA-penlight batteries or Battery Pack SD-7	Battery Pack SD-7	4 AA-penlight batteries	4 AA-penlight batteries
Recycling time**	8sec. w/SD-7: 9.5sec.	w/SD-7: 9.5sec.	11 sec.	8 sec.
Number of flashes**	150, w/SD-7: 270	w/SD-7: 270	100	160
Dimensions (W × H × D)	104 × 276 × 118mm	94 × 217 × 91mm	82 × 166.5 × 100mm	101 × 43 × 90mm
Weight (without batteries)	810g (flash only)	490g (flash only)	485g	300g

\*Varies according to the *f*/stop selected

\*\* Full output with AA-penlight alkaline batteries

# Versatility unlimited.

No other 35 mm camera on the market today can boast of having a system of accessories as all-encompassing as Nikon's. So, regardless of where your thoughts take you in photography, you can record them on film with the Nikon F3.



## Close-Up Equipment

Discover the enchanting world in miniature with Nikon's sophisticated close-up accessories. At the heart of the Nikon system of close-up photography is the Bellows Focusing Attachment PB-6—a unit so superbly crafted that you'll delight in using it. With the twist of a knob you can vary the lens extension at will, producing frame-filling images of the tiniest of subjects. When used with the Double Cable Release AR-7, automatic aperture control is possible even with a lens in the reversed position.

### Extension Bellows PB-6E

Attaches to the PB-6 for magnifications up to an astounding 23X life-size when using a 20mm wide-angle lens in the reverse position.



### Focusing Stage PG-2

Simplifies close-up focusing when the camera or camera plus motor drive are mounted on a tripod.



### Macro Copy Stand PB-6M

Attaches to the end of the PB-6 and functions as a miniature copy stand or specimen stage.





### Repro-Copy Outfit PF-4

For making high-quality photographic copies of photographs, illustrations, drawings, or diagrams.



### Extension Rings

Another easy way of making close-ups. PK-11, 12, and 13 and PN-11 offer automatic aperture operation, while the Extension Ring Set K consists of five rings which can be used singly or in combination.



### Close-Up Attachment Lenses

The simplest and easiest way to shoot at less than 1X magnification, these accessories screw into the front of 52mm or 62mm front-thread lenses to magnify the subject. For superb contrast and color fidelity, all feature Nikon Integrated Coating. Lenses with a "T" indication are for use with telephoto lenses and have 2-element construction.

### Slide Copying Adapter PS-6

Used with the PB-6 to make slide duplicates. Cropping of the original is possible.



### Data Back MF-14



Featuring a quartz-controlled clock, this interchangeable camera back provides a liquid crystal display of the time, date, or frame number from -2 to 2000 and lets you imprint this data in the lower right-hand corner if so desired. The MF-14

also has a built-in alarm, making it very handy for travel. Designed for snapshooters, scientists, or anyone else who wants to create lasting memories.

### Anti-Cold Battery Holder DB-2



Special battery pack holding 2 AA-penlight alkaline batteries which goes inside the coat, allowing the F3 to be used in below-freezing temperatures.

### Camera and Compartment Cases



Handsome and functional, Nikon cases let you carry your equipment in style. Made of genuine leather, Soft Leather Case CS-15 or Semi-Soft Leather Cases CF-21, 21A, and 22 provide needed protection. Or you might consider the stylish Custom Shoulder Cases CB-1, 2, and 3. And for carrying a variety of cameras and accessories, Nikon makes a comprehensive line of

compartment cases ranging in size from the large FB-11A to the compact FB-17.

# Your eyes.

From fisheye to super-telephoto, zoom to perspective-control, micro to reflex, there are no less than 70 Nikkor and Nikon Series E lenses to challenge your imagination. Not that you'll ever need all of them, but at least you have a choice. And for a photographer, the more choices, the better the vision.

But what about image quality? You can rest assured that it is the best there is. All lenses are constructed of the finest Nikon optical glass produced in its own glassworks, while all Nikkor lenses are multicoated, using Nikon Integrated Coating for superior contrast and color rendition. Total interchangeability is insured, thanks to the legendary Nikon bayonet mount, which has remained virtually unchanged since 1959. For easy handling, the overwhelming majority of lenses from 20 to 200mm take standard 52mm filters.

Many lenses also feature one or more optical innovations pioneered by Nikon. Among these are the Close Range Correction (CRC) System to insure exceptional image quality at close distances, Extra-Low Dispersion (ED) glass for correction of chromatic aberration in long telephoto lenses, and Internal Focusing (IF), making focusing totally responsive with no extension in the lens barrel. With the Nikon F3, your seeing is never restricted to conventional ideas.







## Nikkor Lenses

### FISHEYE

6mm f/2.8  
8mm f/2.8  
16mm f/2.8

### WIDEANGLE

13mm f/5.6  
15mm f/3.5  
18mm f/3.5  
20mm f/2.8  
24mm f/2  
24mm f/2.8  
28mm f/2  
28mm f/2.8  
35mm f/1.4  
35mm f/2  
35mm f/2.8

### NORMAL

50mm f/1.2  
50mm f/1.4  
50mm f/1.8

### TELEPHOTO

85mm f/1.4  
85mm f/2  
105mm f/1.8  
105mm f/2.5  
135mm f/2  
135mm f/2.8  
180mm f/2.8 ED  
200mm f/2 IF-ED  
200mm f/4  
300mm f/2 IF-ED  
300mm f/2.8 IF-ED  
300mm f/4.5  
300mm f/4.5 IF-ED  
400mm f/2.8 IF-ED  
400mm f/3.5 IF-ED  
400mm f/5.6 IF-ED  
500mm f/4 IF-ED P\*  
600mm f/4 IF-ED  
600mm f/5.6 IF-ED  
800mm f/5.6 IF-ED  
800mm f/8 IF-ED  
1200mm f/11 IF-ED

### REFLEX

500mm f/8  
1000mm f/11  
2000mm f/11

### ZOOM

28-85mm f/3.5-4.5  
35-70mm f/3.5-4.5  
35-70mm f/3.5  
35-105mm f/3.5-4.5  
35-135mm f/3.5-4.5  
35-200mm f/3.5-4.5  
80-200mm f/4  
50-300mm f/4.5 ED  
100-300mm f/5.6  
200-400mm f/4 ED  
180-600mm f/8 ED

### SPECIAL PURPOSE

PC 28mm f/3.5  
PC 35mm f/2.8  
Noct 58mm f/1.2  
Micro 55mm f/2.8  
Micro 105mm f/2.8  
Micro 200mm f/4 IF  
Medical 120mm f/4 IF  
105mm f/4.5 UV

### NIKON SERIES E

28mm f/2.8  
135mm f/2.8

### TELECONVERTER

TC-14A  
TC-14B  
TC-20I  
TC-30I

\*CPU built-in. Available soon.

## Specifications

### Type of camera

35 mm single-lens reflex

### Picture format

24 mm x 36 mm (35 mm film format)

### Lens mount

Nikon bayonet type

### Lenses

Nikkor 50mm f/1.2, 50mm f/1.4, 50mm f/1.8 as standard; more than 70 Nikkor and Nikon Series E lenses are usable

### Shutter

Electromagnetically controlled, horizontal-travel, titanium foil focal-plane shutter

### Shutter release button

Switches meter on when depressed halfway (after shutter release lock is released), meter then remains on for 16 sec. after finger is taken off button; threaded in the center to accept standard cable release

### Automatic exposure control

Aperture-priority automatic exposure control; stepless shutter speeds from 8 sec. to 1/2000 sec.

### Manual exposure control

Quartz digital control for 16 shutter speeds from 8 sec. to 1/2000 sec. including X (1/80 sec.); B and T also provided

### Mechanical shutter control

Possible at T setting on shutter speed dial or at approx. 1/60 sec. when using backup mechanical release lever

### Backup mechanical release lever

Trips shutter at approx. 1/60 sec. regardless of shutter speed dial setting (except T); used when batteries become weak or exhausted, or none are installed in the camera

### Exposure metering

TTL center-weighted full-aperture metering; aperture stop-down metering possible; silicon photodiode (SPD) and metering circuits incorporated into camera body; meter works with all interchangeable viewfinders

### Metering range

EV 1 to EV 18 (i.e., 1/1.4 at 1 sec. to 1/11 at 1/2000 sec. with 50mm f/1.4 lens and ASA/ISO 100 film)

### Film speed setting

ASA/ISO 12 to 6400

### Exposure memory lock

Via button

### Exposure compensation

Via dial; +2 to -2 EV in one-third increments

### Focusing screen

Type K as standard; interchangeable with 21 other types

### Viewfinder\*

Nikon F3: Eyelevel Finder DE-2 as standard; Nikon F3 High-Eyepoint: eyelevel High-Eyepoint Finder DE-3 as standard; both equipped with eyepiece shutter; each interchangeable with 4 other types

### Finder coverage

Virtually 100%

### Finder magnification\*

Nikon F3: 0.8X; Nikon F3 High-Eyepoint: 0.75X (both with 50mm lens set at infinity)

### Viewfinder display

Liquid crystal display (LCD) shows shutter speed; on Auto, +2000 indicates overexposure, -8- underexposure; on Manual, M appears with + indicating overexposure, - underexposure, and - + correct exposure; LED ready-light glows when Speedlight SB-16A and SB-17, plus SB-11 and SB-14 with TTL

Sensor Cord SC-12, is completely recycled; aperture in use also shown through aperture direct-readout (ADR) window

### Viewfinder illuminator

Via button; illuminates both LCD and ADR 1/number

### Multiple exposure control

Via lever

### Depth-of-field preview

Via button; coaxial with the mirror lockup lever

### Reflex mirror

Automatic instant-return type with lockup facility; incorporates air damper and brake mechanism for reduced vibration and noise

### Self-timer

Quartz-controlled 10 sec. delayed exposure; LED blinks at 2 Hz for first 8 sec., then at 8 Hz for last 2 sec.; setting cancellable

### Film advance lever

Wound in single stroke or series of strokes; 30° stand-off angle and 140° winding angle; automatic film advance possible when Motor Drive MD-4 is used

### Film rewind

By crank after film rewind button is depressed; automatic film rewind possible when MD-4 is used

### Frame counter

Additive type; frame numbers from 0 to 40; automatically reset when camera back is opened

### Flash synchronization

Possible at all speeds up to 1/80 sec. with electronic flash; with SB-16A and SB-17, plus SB-11 and SB-14 with TTL Sensor Cord SC-12, sync speed is automatically set to 1/80 sec. with dial at A or 1/125 sec. and above; at 1/60 sec. or slower, flash synchronizes with speed setting as set; threaded sync terminal provided for off-camera or multiple-flash photography

### Accessory shoe

Provided; special Nikon F3 type located at base of rewind knob; accepts Speedlight SB-16A, SB-17 or TTL Sensor Cord SC-12 from SB-11 or SB-14 for TTL direct flash output control; two types of flash couplers available for mounting ISO-type or F2-type direct mounting flash units

### Motor drive coupling

Electrical contacts and mechanical couplers provided for operation with Motor Drive MD-4

### Camera back

Hinged; opened by pushing safety lock while pulling up rewind knob; memo holder provided; interchangeable with Camera Back MF-6, Data Back MF-14, or 250 Exposure Magazine Back MF-4

### Power source

Two 1.55V silver-oxide batteries (S-76 or SR-44 type), two 1.5V alkaline-manganese batteries or one 3V lithium battery (CR-1 3N type); when Motor Drive MD-4 is attached, camera gets battery power entirely from batteries in motor drive

### Body finish

Black only

### Body dimensions\* (W x H x D)

Nikon F3: Approx. 148.5 mm x 96.5 mm x 65.5 mm;

Nikon F3 High-Eyepoint: Approx. 148.5 mm x 101.5 mm x 69 mm

### Body weight\*

Nikon F3: Approx. 715g;

Nikon F3 High-Eyepoint: Approx. 760g

**Note:** The Nikon F3 and F3 High-Eyepoint have the same specifications except those items indicated by an asterisk (\*).

Specifications and designs shown herein are subject to change without notice.

## Nikon Photo Contest International

Each year since 1969, Nikon's prestigious contest gives amateur and professional photographers the opportunity to match skills with fellow photographers from around the globe. Entry forms and rules are available from your local Nikon distributor.



## IMAGING TECHNOLOGIES FROM NIKON

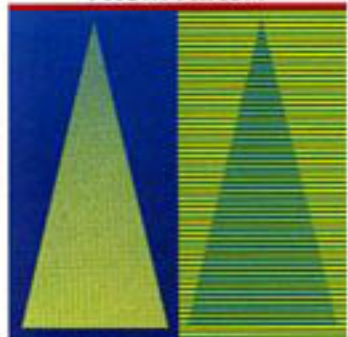

**Nikon**

NIPPON KOGAKU K.K.

(NIKON CORPORATION as of April 1, 1988)

Fuji Bldg., 2-3, Marunouchi 3-chome, Chiyoda-ku, Tokyo 100, Japan

Phone: 81-3-214-5311 Telex: J22601 (NIKON) Fax: 81-3-201-5856

Printed in Japan (8711/B)

Code No. BCE40100

**Nikon**