

作成承認印	配布許可印

# Nikon F5

REPAIR MANUAL

**Nikon** | NIKON CORPORATION  
Tokyo, Japan

# SPECIFICATIONS

## CONTENTS

	Page
1. AUTOFOCUS .....	M1
2. EXPOSURE MEASUREMENT .....	M2
3. EXPOSURE CONTROL .....	M4
4. FILM OPERATION .....	M17
5. FOCUSING SCREEN .....	M18
6. FINDER .....	M19
7. POWER SOURCE .....	M19
8. DATA BACK CONTACTS .....	M19
9. MODIFYING CAMERA .....	M20
10. TIME CHARTS .....	M21

# SPECIFICATIONS

(The following specifications and mechanical explanations are not included in other instruction manuals or brochures.)

## 1. AUTOFOCUS

### 1-1. Focus Tracking

- In Continuous Servo AF or Single Servo AF, Focus Tracking is automatically activated for moving subjects, regardless of film advance mode.
- Focus Tracking is activated regardless of the focus area set.
- With the DW-30/DW-31 attached, exposure metering is performed by the AF CCD sensor. With subjects of -10 EV or darker, the microcomputer's calculation speed for AF operation slows and Focus Tracking performance may deteriorate. When set for Focus-Priority, the shooting speed slows. When set for Shutter-Priority, Focus Tracking response time slows and autofocus may be impossible with darker subjects. All of these occur regardless focus area.
- When Focus Tracking is activated by a moving subject, you can release the shutter when you expect the subject to be in focus, even in Focus-Priority shooting.

### 1-2. Focus Area

#### 1-2-1. AF area mode

- Two AF Area modes are available, Single Area AF and Dynamic AF. To select either, rotate the Main-Command Dial while pressing AF Area button.
  - Single Area AF mode:  
User can select the desired focus area. The focused distance is calculated **exclusively** by the sensor for the selected focus area.
  - Dynamic AF mode:  
User selects the priority focus area that best suits the **desired composition**. **If the subject moves out of the selected focus area, Dynamic AF instantly shifts to the new focus area to keep the subject in focus. Focus area indication does not change.** Using the PC software for the F5, you can limit selectable focus areas for Dynamic AF.

#### 1-2-2. Selecting focus area

- User selects one of the five focus areas.  
Selected focus area remains unchanged when the AF area mode changes.
- To select the focus area, press the focus area selector. Pressing top, bottom, left or right on the focus area selector shifts the selected focus area in a corresponding direction. Diagonal shift can also be performed (to switch to the top area from the left focus, for example, press top on the selector, without first selecting center; to switch to the bottom area, press down on the selector). With the DW-30/DW-31 attached, right and left indications are reversed.

- With the standard EC-B screen, the selected focus area is displayed in the LCD. The focus area indicator inside the viewfinder can be seen with any type of screen.
- To lock the focus area, while pressing the lock button press the focus area selector to designate the desired area. To release the lock, press the focus area selector while pressing the lock button again. Performing Two-Button Reset or turning the camera's power off will also release the lock.
- Pressing one direction on the focus area selector with focus area selector already pressed to another direction shifts focus area.

### 1-3. Scan-Driving—Re-Autofocusing with Large Defocus Amount

- If the amount of defocus detected in the selected area exceeds a specified value, the lens begins autofocusing again (scan-driving). At low brightness, the scan-driving speed slows. If the subject is brighter than EV 8, it performs high-speed scan-driving. If the subject brightness is EV 4 or darker, it performs low-speed scan-driving at a specified fixed speed. Between EV 8 and EV 4, scan-driving speed gradually slows at a linear rate.
- In Dynamic AF mode, if the amount of defocus detection in the selected area exceeds a specified value, scan-driving can be performed only within the selected area. If no in-focus subject is detected in any of the five areas, scan-driving is not performed. For autofocus using the focus-assist illuminator, focus detection is not performed after scan-driving. To restart autofocus, lightly press the shutter release button.
- With the Speedlight's focus-assist illuminator, focus detection is performed once. To restart autofocus, lightly press the shutter release button.

## 2. EXPOSURE MEASUREMENT

### 2-1. TTL Full-Aperture Measurement

- With AI-type Nikkor lenses (including AI-modified Nikkor lenses), TTL full-aperture measurement is performed.
- With the standard DP-30 finder, three types of exposure metering systems are available—3D Color Matrix Metering, Center-Weighted Metering and Spot Metering. With other optional finders, available metering systems are more limited.
- Metering system availability depends on the lens attached.
- Available metering systems are as follows:
  - With the standard DP-30 finder—3D Color Matrix Metering, Center-Weighted Metering and Spot Metering can be performed with the 1,005-segment Advanced Matrix Sensor inside the DP-30 finder.
  - With the DW-30/DW-31 finder—Spot Metering can be performed with the central CCD sensor inside the camera body.
  - With the DA-30 finder—five-segment Matrix Metering, Center-Weighted Metering and Spot Metering can be performed with the SPD sensor (same type as for the F50) inside the finder.

- In **Center-Weighted Metering** with the DP-30 finder, **75%** of the meter's sensitivity is concentrated in the 12mm-dia. circle within the viewfinder. The F5's Custom Setting function lets you change the size of the circle to 8mm, 15mm or 20mm. You can also average meter sensitivity for the entire viewfinder. Custom Settings are set on the camera body (not the viewfinder).
- With the DP-30 finder, EC-B screen and CPU lens, when Spot Metering is set, shifting the focus area shifts the Spot Metering area accordingly, regardless of AF Area mode. (See table below.)

DP-30 finder	EC-B screen		Screen other than EC-B-type
	CPU lens	Non-CPU lens	CPU lens and non-CPU lens
Spot Metering sensitivity	Concentrated on the 4mm-dia. area selected	Concentrated on only center 4mm-dia. area	Concentrated on only center 6mm-dia. area

- With the DP-30 and the EC-B screen, in Spot Metering nearly 100% of the meter's sensitivity is concentrated on the 4mm-dia. area within the selected focus area of the viewfinder.
- With the DW-30/DW-31 finder, in Spot Metering the SPD sensor inside the camera body is used and nearly 100% of meter's sensitivity is concentrated on the 3mm-dia. area (with CPU lenses only).
- With the DA-30 finder, available metering systems depend on the screen/lens combination, as shown below.

DA-30 finder	EC-B screen		Screen other than EC-B-type	
	CPU lens	Non-CPU lens	CPU lens	Non-CPU lens
<b>Matrix</b>	Five-segment Matrix	Center-Weighted	Five-segment Matrix	Center-Weighted
<b>Center-Weighted</b>	Center-Weighted	Center-Weighted	Center-Weighted	Center-Weighted
<b>Spot</b>	Spot with finder's sensor		Spot with body's sensor	—

- **Metering range** at ISO 100, normal temperature is:
  - Matrix: EV 0 to EV 20
  - Center-Weighted: EV 0 to EV 20
  - Spot (with finder's sensor): EV 2 to EV 20
  - Spot (with body's sensor): EV 2 to EV 17
- With the DP-30 finder, the SPD is not used for metering. In continuous shooting at low brightness and high temperatures, in order to maintain the specified shooting speed, the camera measures only the exposure for the first frame.

### 3. EXPOSURE CONTROL

#### 3-1. Exposure Modes

- Four exposure modes are available—Programmed Auto, Shutter-Priority Auto, Aperture-Priority Auto and Manual.

##### 3-1-1. Programmed Auto

- Can be set with CPU lenses (AF-S-Nikkor, AF-I-Nikkor, D-type AF Nikkor, non-D-type AF Nikkor and AI-P-type Nikkor) only.
- With non-CPU lens, exposure mode automatically switches to Aperture-Priority Auto.
- The Main-Command Dial is rotated for Flexible Program function.
- The Flexible Program function temporarily changes an automatically set shutter speed/aperture combination while maintaining the same exposure. The F5's Flexible Program is designed to move the program line horizontally. At the maximum or minimum lens aperture, the shutter speed/aperture combination is not be shifted. (Flexible Programs for the F5 and F50 vary in this respect.)
- Program can be shifted within  $\pm 5$  EV.
- The shutter speed/aperture combination changes in  $1/3$  EV steps. Rotating the Main-Command Dial clockwise sets a slower shutter speed and wider aperture; rotating it counterclockwise sets a faster shutter speed and narrower aperture.
- While shifting programs, the Flexible Program indicator ( $P^+$ ) appears in the top LCD panel.
- Flexible Program is canceled when you turn the camera's power off, switch to another exposure mode, or perform Two-Button Reset. Flexible Program remains active when you remove a CPU lens and Programmed Auto exposure mode automatically switches to Aperture-Priority Auto.
- Changes in the shutter speed/aperture combination are displayed in the top LCD panel and inside viewfinder in  $1/3$  steps.
- If the lens is not set at its minimum aperture (if it is set to an aperture at least  $1/3$  step wider than the minimum aperture),  $FE E$  blinks (at 1 Hz) in the top LCD panel and inside the viewfinder.
- When exposure is compensated or when Auto Exposure Bracketing is performed, the program is adjusted to match the specified program line shown in the program chart.
- The following shows the F5's program chart (same as for F4):

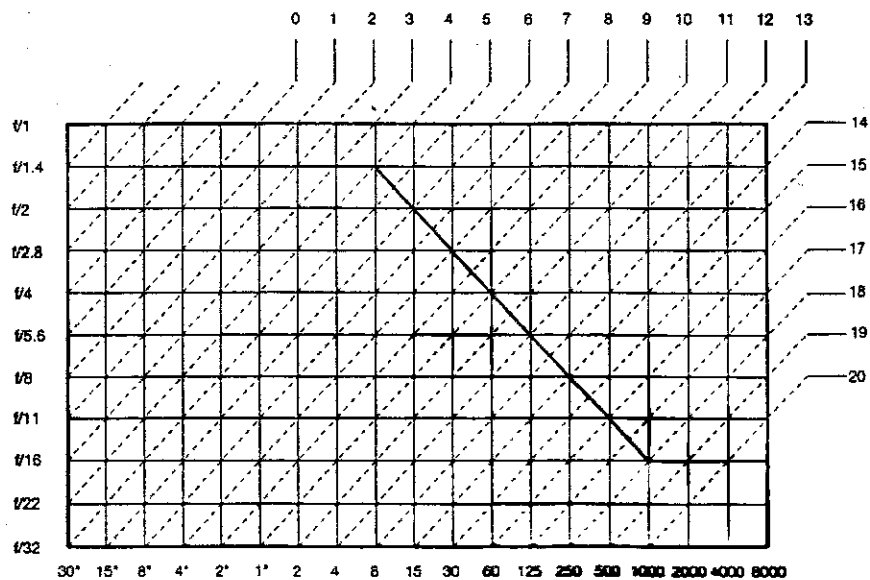

### 3-1-2. Aperture-Priority Auto

- Can be set with AI-type Nikkor (including AI-modified Nikkor) or later lenses.
- With non-CPU lens, aperture setting operations are performed using the lens aperture ring.
- With a non-CPU lens, the aperture setting can be confirmed with the lens' aperture-direct-readout scale in the viewfinder window. The top LCD panel and viewfinder show F - -.
- With the CPU lens set to its minimum aperture, aperture setting operations are performed using the camera's Sub-Command Dial. (Rotating the Sub-Command Dial one click clockwise narrows the aperture by 1/3 step.) Intermediate settings between the 1/3 steps can be selected **only** when the lens is set to its maximum aperture. Intermediate settings (1/4, 1/2, etc.) other than 1/3 step can be selected **only** for the maximum aperture of the lens.
- With CPU lenses, aperture can also be set by rotating the lens aperture ring. With the aperture ring at a setting other than the minimum setting, the top LCD panel and viewfinder show F - -. The aperture can be confirmed using the lens' aperture-direct-readout scale in the viewfinder window.
- With a CPU lens, the aperture set on the camera body is indicated in the top LCD panel and inside the viewfinder. The indication changes in 1/3 steps.
- In Aperture-Priority Auto exposure mode, the shutter speed is controlled between 32 sec. and 1/8096 sec. (between 30 sec. and 1/8000 sec. in the display).
- With a non-AI-type Nikkor lens, stop-down measurement can be performed **only** in Aperture-Priority Auto exposure mode.
- When you use the Custom Setting function to disable aperture settings via the Sub-Command Dial (# 22 of the Custom Setting Menu), aperture setting operations for CPU lenses can **only** be performed with the lens aperture ring.
- Using the Sub-Command Dial, you can set any aperture between the lens' **maximum and** minimum apertures.

### 3-1-3. Shutter-Priority Auto

- Can be set with CPU lenses (AF-S-Nikkor, AF-I-Nikkor, D-type AF Nikkor, **non-D-type** AF Nikkor and AI-P-type Nikkor) *only*.
- With a non-CPU lens, the exposure mode automatically switches to Aperture-Priority Auto.

- **Shutter speed** is selected by rotating the **Main-Command Dial**; to select a faster shutter speed, rotate clockwise.
- The selected shutter speed is indicated in the top LCD panel and inside the viewfinder. The indication **changes** in 1/3 steps.
- “Bulb” cannot be set in Shutter-Priority Auto exposure mode. If you set “Bulb” in Manual exposure mode, then switch exposure modes to Shutter-Priority Auto, the shutter locks and **bulb** blinks (at 1 Hz) in the top LCD panel. If this happens, change the shutter speed to another setting.
- Shutter speed is set between 32 sec. and 1/8092 sec. (and displayed between 30 sec. and 1/8000 sec.). X setting (1/60 sec., 1/80 sec., 1/100 sec., 1/125 sec., 1/160 sec., 1/200 sec., 1/250 sec., or 1/300 sec.) is also available.
- If the lens is not set to its minimum aperture (if it is set to an aperture 1/3 step wider than its minimum aperture), **fEE** blinks (at 1 Hz) in the top LCD panel and inside the viewfinder.
- When the selected shutter speed requires an aperture beyond the available aperture range, the shutter speed will not shift automatically.
- The prolonged shutter speeds of the Custom Setting function are not available in Shutter-Priority Auto exposure mode.
- Rotation of the Main-Command Dial is limited at its slowest end (X setting) and fastest end (1/8000 sec.).

#### 3-1-4. Manual

- With a non-CPU lens, aperture setting operations are performed using the lens aperture ring.
- With a non-CPU lens, the aperture setting can be confirmed using the lens’ aperture-direct-readout scale in the viewfinder window. The top LCD panel and viewfinder show **F - -**.
- With a CPU lens set to its minimum aperture, aperture setting operations are performed using the camera’s Sub-Command Dial. (Rotating the Sub-Command Dial **one clockwise click** narrows the aperture by 1/3 step.) Only for the lens maximum aperture, **intermediate** settings other than 1/3 step can be selected.
- Automatic shutter speed control is not performed according to the Sub-Command Dial aperture setting.
- With a CPU lens, you can also set the aperture by rotating the lens aperture ring. (When lens aperture ring is rotated from its minimum setting to another setting, the setting on the aperture ring will be effective. If the aperture ring is re-set to its minimum aperture setting, however, it will revert to the previous aperture set on the camera body.) With the aperture ring set to a setting other than the minimum setting, the top LCD panel and viewfinder show **F - -**. Aperture can be confirmed on the lens’ aperture-direct-readout scale in the viewfinder window.
- With a CPU lens, the aperture set on the camera body is indicated in the top LCD panel and inside the viewfinder. The indication changes in 1/3 steps.
- Apertures are provided on the board for the AI-ring in 1/6 step increments. The camera, however, is able to convert these to finer aperture settings.



- **Shutter speed** is selected by rotating the Main-Command Dial; to select a faster shutter speed, rotate clockwise. Shutter speed order: X setting, Bulb setting, slowest shutter speed → fastest shutter speed. This order is maintained even if the Custom Setting function is used to prolong the slowest shutter speed.
- The selected shutter speed is indicated in the top LCD panel and inside the viewfinder. The indication changes in 1/3 steps.
- The shutter speed is set between 32 sec. and 1/8092 sec. (and displayed between 30 sec. and 1/8000 sec.). X setting (1/60 sec., 1/80 sec., 1/100 sec., 1/125 sec., 1/160 sec., 1/200 sec., 1/250 sec., or 1/300 sec.) is also available.
- At 1/250 sec. and 1/300 sec., the controlled shutter speed is 1/12 EV longer than the calculated shutter speed value.
- X setting is situated at the one end of shutter speed range, 1/8000 sec. at the other end.
- The Custom Setting function allows you to prolong the shutter speed for Long Time Exposures. (See 3.6.3.1 for selectable shutter speeds.) When the shutter speed is prolonged, the electronic analog display inside the viewfinder disappears. Setting a prolonged shutter speed in Manual exposure mode then switching exposure mode to Shutter-Priority Auto sets the shutter speed to 30 sec. Switching the exposure mode back to Manual does not re-activate prolonged shutter speed.
- When the shutter speed is prolonged to 40 sec. or slower (using the Custom Setting function on the camera body or Photo Manager), Auto Exposure Bracketing can be set (on the camera body, MF-28 or with Photo Manager) but shutter speed does not vary.
- When the shutter speed is prolonged (using the Custom Setting function on the camera body or PC-Link) and the prolonged shutter speed is faster than 40 sec., you can perform Auto Exposure Bracketing (with camera body, MF-28 or Photo Manager).

### 3-1-5. Control of Bulb setting

- When bulb is set, depressing the shutter release button opens the shutter and lightly pressing the shutter release button closes the shutter.
- When Time setting is selected in place of Bulb setting using Photo Manager's Custom Setting function, depressing the shutter release button opens the shutter and depressing it again closes the shutter. If the self-timer is activated at the Bulb setting, the shutter opens when self-timer operation is complete and closes when the shutter is depressed.
- When Time setting is selected in place of Bulb setting using Photo Manager's Custom Setting function, the Long Time Exposure function of the MF-28 cannot be set.

### 3-2. Auto Exposure Bracketing

- Rotating the Main-Command Dial while pressing the BKT (Auto Exposure/Flash Exposure Bracketing) button activates Auto Exposure Bracketing/Flash Exposure Bracketing mode. When the BKT button is pressed, the rear LCD panel shows the number of shots and compensation value. When Auto Exposure Bracketing/Flash Exposure Bracketing mode is activated, the top and rear LCDs show the BKT symbol. With Auto Exposure Bracketing/Flash Exposure Bracketing mode active, the BKT symbol remains whether the BKT button is pressed or not. While the BKT button is pressed, the rear LCD panel shows only the BKT symbol.
- Rotating the Main-Command Dial while pressing the BKT button (whether Auto Exposure Bracketing/Flash Exposure Bracketing mode is activated or not) changes the number of shots/compensation value combination.

- Nine combinations of number of shots and compensation values are available as shown below:

Number of shots	Compensated EV value
(1) Two	0 and +1/3
(2) Two	0 and -1/3
(3) Two	0 and +2/3
(4) Two	0 and -2/3
(5) Two	0 and +1
(6) Two	0 and -1
(7) Three	0, -1/3 and +1/3
(8) Three	0, -2/3 and +2/3
(9) Three	0, -1 and +1

Rotating the Sub-Command Dial counterclockwise lets you select these combinations in the following order:

(1) → (3) → (5) → (2) → (4) → (6) → (7) → (8) → (9)

- Rotating the Main-Command Dial while pressing the BKT button again cancels Auto Exposure/Flash Exposure Bracketing mode.
- After canceling Auto Exposure Bracketing/Flash Exposure Bracketing mode, your selected number of shots/compensation value combination will be set.
- When Auto Exposure Bracketing is set using the MF-28 or Photo Manager, the camera body's Auto Exposure/Flash Exposure Bracketing will not function. Indications for the camera body's Auto Exposure/Flash Exposure Bracketing are displayed in the camera's LCD panel, however, and the number of frames and compensation degree can be adjusted.
- With the Custom Setting function set at 3-1 and the BKT button depressed, the top LCD panel and viewfinder LCD show the compensated shutter speed and compensated aperture value. The electronic analog display also shows the compensated value. Other indications remain unchanged. (With the Custom Setting function at 3-0, the first shot is taken without compensation, so the shutter speed and aperture indications and electronic analog display do not change.)
- When you prolong the shutter speed, Auto Exposure Bracketing can be set but the shutter speed will not vary. (See 3.1.4.)
- Custom Setting #3 can be used to change the bracketing order. At the default setting in bracketing, shots are taken in the order from no compensation to negative compensation to positive compensation. With Custom Setting function 3-1, the bracketing order is: negative compensation, no compensation then positive compensation. The default order is applied when Auto Exposure Bracketing is set with the Photo Manager. When Auto Exposure Bracketing is set with the MF-28, shot with center value is taken at first. (If number of shots is set at two, the shot with no compensation will be taken at first.)
- With Custom Setting #24, you can perform only Auto Exposure Bracketing or Flash Exposure Bracketing.
- When X setting is selected in Manual exposure mode, the shutter speed will not vary in bracketing.

### 3-2-2. Exposure Mode and Auto Exposure /Flash Exposure Bracketing

- In **Programmed Auto** exposure mode, the shutter speed and aperture will vary. (They may not vary at the same time.)
- In **Aperture-Priority Auto** exposure mode, the shutter speed varies.
- In **Shutter-Priority Auto** exposure mode, the aperture varies.
- In **Manual exposure** mode, the shutter speed varies. The top LCD panel and viewfinder LCD show the controlled shutter speed and indications remain as long as the exposure meter is active. (With the Custom Setting function, if the shutter speed/aperture or aperture only is selected as the shifting factor for bracketing, the controlled aperture will be displayed in the top LCD panel and inside the viewfinder.)
- In any exposure mode, the flash output level also varies.
- At bulb setting, only the flash output level varies.
- Custom Setting # 17 changes the shifting factor as follows:

Shifting factor	Shutter speed	Aperture	Flash output level
Shutter speed only	Varies at the compensation value set	-	Varies at the compensation value set
Aperture only	-	Varies at the compensation value set	Varies at the compensation value set
Shutter speed/aperture combination	Varies at half of the compensation value set	Varies at half of the compensation value set	Varies at the compensation value set
Flash output level	-	-	Varies at the compensation value set

### 3-2-3. Auto Exposure/Flash Exposure Bracketing operation

- With the film advance mode at CH, CL or Cs, fully depressing the shutter release button and holding it in automatically triggers the set number of shots and stops the film advance.
- With the film advance mode set at S, fully depressing the shutter release button takes one shot.
- If you reach the end of the film roll during shooting, simply replace the film with a new one then fully depress the shutter release button to resume operation.

### 3-2-4. Indications for Auto Exposure/Flash Exposure Bracketing

- The 4-digit, 7-segment indication in the Rear LCD panel shows the number of shots and compensation value. The bracketing bar graph also appears in the rear LCD panel.
- See 3.6.3.2 for type of indications.
- With the Auto Exposure/Flash Exposure Bracketing set, the BKT symbol is shown in the top and rear LCD panels.
- When Auto Exposure/Flash Exposure Bracketing is set, the exposure compensation symbol blinks (at 1 Hz) in the top LCD panel and inside the viewfinder.

### 3-2-5. Setting only Auto Exposure Bracketing or Flash Exposure Bracketing

- Custom Setting #24 enables you to perform only Auto Exposure Bracketing or Flash Exposure Bracketing.

Bracketing	Exposure	Flash output level
Auto Exposure Bracketing only	Varies at the compensation value set	-
Flash Exposure Bracketing only	-	Varies at the compensation value set
Auto Exposure/ Flash Exposure Bracketing	Varies at the compensation value set	

### 3-3. Self-Diagnostic Shutter System

#### 3-3-1. Shutter speed compensation

- The final compensation value  $\Delta T$  is calculated using temperature data and the temperature compensation curve stored in the camera's computer (shown below).  $\Delta T$  is added to the shutter speed for the next release of the shutter.
- The diagram below shows the temperature compensation curve:

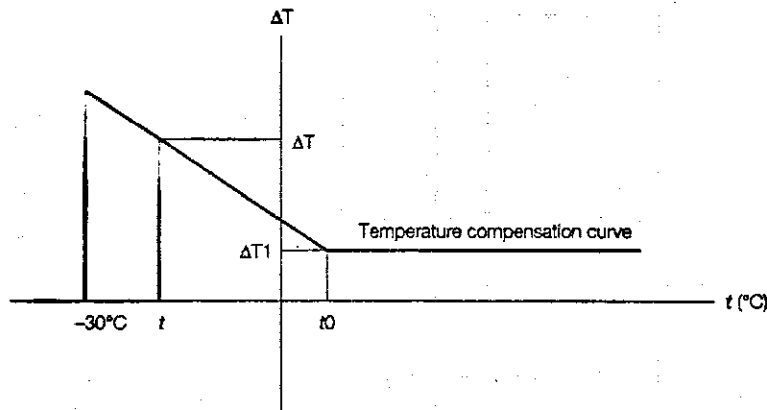

#### 3-3-2. After shutter traveling

- Data sampling is performed for all shutter speed values.
- The front shutter curtain is monitored for 10msec. immediately before the front curtain Mg is off; the rear shutter curtain is monitored for 10msec. just before the rear curtain Mg is off.
- If shutter speed accuracy for the previous shutter release varies by more than  $\pm 1.0$  EV, the shutter blades are considered damaged and the shutter speed will not be compensated.

### 3-3-3. Shutter blade damage errors

- If shutter-monitor sensor output data indicates that (a) shutter speed accuracy exceeds a specified EV value, (b) the shutter curtains did not open, (c) the shutter curtains opened twice, (d) shutter curtains do not close, or (e) shutter curtains open immediately after shutter release, shutter blades are judged as damaged. Following shows output data:

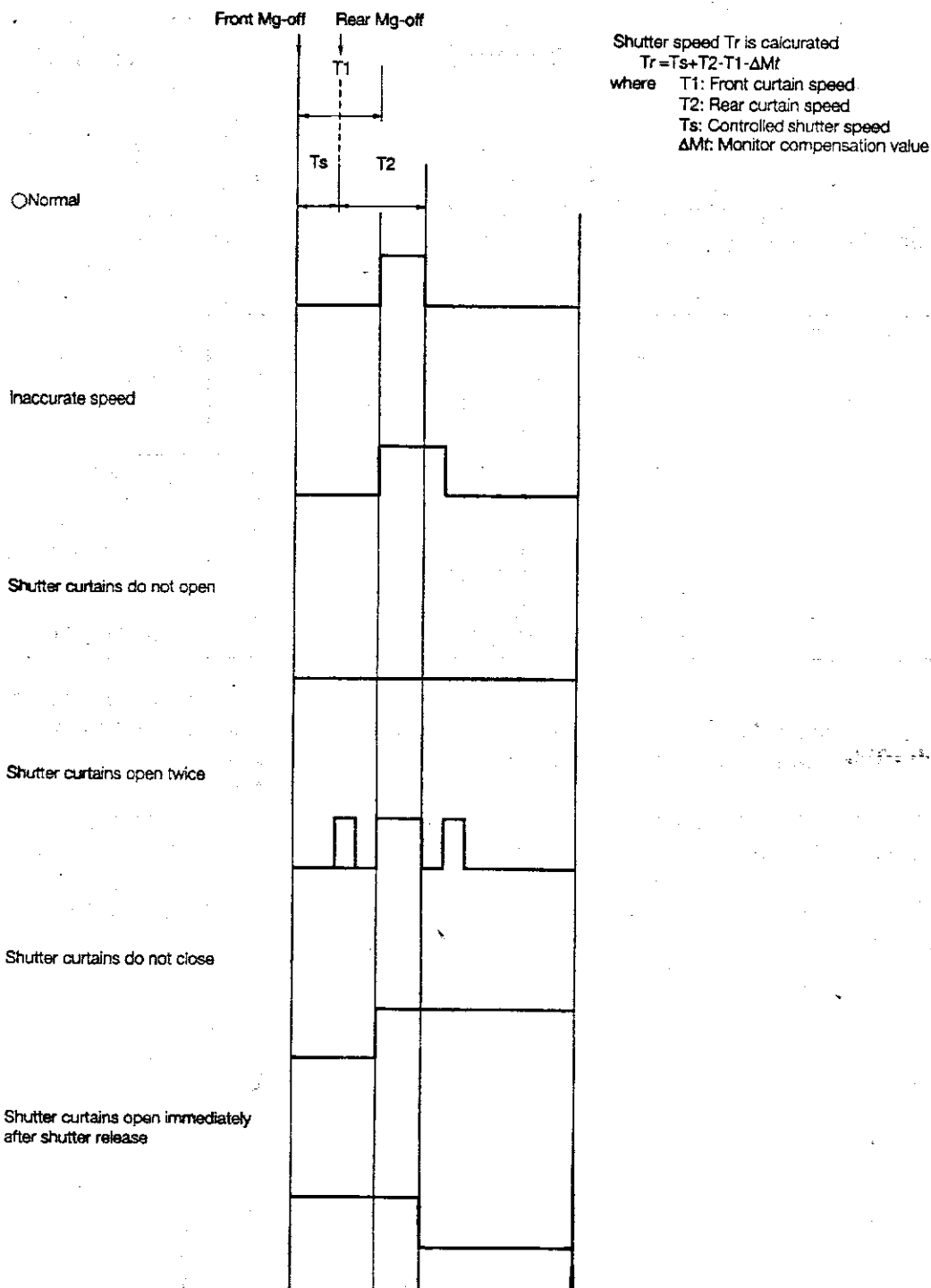

### 3-3-4. Shutter blades damage alert and locking shutter

- If one of the previously mentioned malfunctions is detected, the shutter blades will be judged as **damaged**. Shutter blades damage alerts will appear and the shutter locks.
- Shutter blades damage alerts consist of:
  - Top LCD panel shows blinking **Err** (at 1 Hz) in place of the shutter speed indication.
  - Viewfinder LCD shows blinking **Err** (at 1 Hz) in place of the shutter speed indication.
  - The alert LED blinks (at 8 Hz)
- When the exposure meter automatically turns off, these alerts disappear and the shutter can be released.

### 3-4. Lens Compatibility

#### 3-4-1. Compatibility of lenses, focusing, exposure modes and metering systems

- The table below shows compatibility of CPU lenses, focusing, exposure modes and metering systems:

		Focusing		Exposure mode				Metering system		
		AF	MF with electronic rangefinder	P	S	A	M	Matrix	CW	Spot
CPU lens	AF-I Nikkor	○	○	○	○	⊙ <sup>1</sup>	⊙ <sup>1</sup>	○	⊙ <sup>2</sup>	⊙ <sup>3</sup>
	D-type AF Nikkor	○	○	○	○	⊙ <sup>1</sup>	⊙ <sup>1</sup>	○	⊙ <sup>2</sup>	⊙ <sup>3</sup>
	AF Nikkor	○	○	○	○	⊙ <sup>1</sup>	⊙ <sup>1</sup>	○	⊙ <sup>2</sup>	⊙ <sup>3</sup>
	AI-P Nikkor	○ <sup>4</sup>	○ <sup>5</sup>	○	○	⊙ <sup>1</sup>	⊙ <sup>1</sup>	○	⊙ <sup>2</sup>	⊙ <sup>3</sup>

- 1: Aperture can be set using the Sub-Command Dial.
- 2: Size of the circle where meter sensitivity is concentrated can be changed.
- 3: With the DP-30 finder and EC-B-type screen, shifting the focus area also shifts the **Spot Metering** area accordingly.
- 4: Possible with TC-16A attached; maximum effective aperture is f/5.6 or faster. (With a maximum effective aperture slower than f/5.6, focus indication can be seen but is not reliable.)
- 5: Possible with a maximum aperture of f/5.6 or faster.

- The table below shows compatibility of non-CPU lenses, focusing, exposure modes and metering systems:

		Focusing		Exposure mode				Metering system		
		AF	MF with electronic rangefinder	P	S	A	M	Matrix	CW	Spot
Non-CPU lens	AI-S-type Nikkor	○ <sup>1</sup>	○ <sup>2</sup>	×	×	○	○	×	○	○
	AI-type Nikkor	○ <sup>1</sup>	○ <sup>2</sup>	×	×	○	○	×	○	○
	AI-modified Nikkor	×	○ <sup>2</sup>	×	×	○	○	×	○	○
	Non-AI-type Nikkor <sup>3</sup>	×	○ <sup>2</sup>	×	×	○ <sup>4</sup>	○ <sup>5</sup>	×	○ <sup>6</sup>	○ <sup>6</sup>
	Medical-Nikkor 120mm f/4	×	×	×	×	×	○ <sup>7</sup>	×	○ <sup>6</sup>	○ <sup>6</sup>
	Reflex-Nikkor	×	×	×	×	○	○	×	○ <sup>8</sup>	○ <sup>8</sup>
Accessory	PC-Nikkor	×	×	×	×	○ <sup>9</sup>	○ <sup>10</sup>	×	○	○
	TC-16A	○ <sup>11</sup>	×	×	×	○	○	×	○ <sup>12</sup>	○ <sup>12</sup>
	AI-S-type teleconverter	×	○ <sup>13</sup>	×	×	○	○	×	○ <sup>12</sup>	○ <sup>12</sup>
	AI-type Teleconverter	×	○ <sup>13</sup>	×	×	○	○	×	○ <sup>12</sup>	○ <sup>12</sup>
	PB-6B	×	○ <sup>13</sup>	×	×	○ <sup>14</sup>	○ <sup>5</sup>	×	○ <sup>15</sup>	○ <sup>15</sup>
	PK Rings	×	○ <sup>13</sup>	×	×	○ <sup>16</sup>	○ <sup>16</sup>	×	○ <sup>15</sup>	○ <sup>15</sup>

- 1: Possible with TC-16A attached; the maximum effective aperture is f/5.6 or faster. (With a maximum effective aperture slower than f/5.6, focus indication can be seen but is not reliable.)
- 2: Possible with a maximum aperture of f/5.6 or faster.
- 3: Requires AI-modification at a Nikon service facility.
- 4: By stop-down metering (i.e., releasing the shutter while pressing the depth-of-field preview button)
- 5: By stop-down metering.
- 6: By stop-down metering. At aperture settings other than the maximum aperture, focusing screen compensation of +0.5 EV is required using Custom Setting #18.
- 7: Can be used at 1/125 sec. or slower.
- 8: Some lens/finder combinations require focusing screen compensation using Custom Setting #18.
- 9: By stop-down metering. Exposure is determined by presetting the lens aperture before shifting. AE-L function should be used before shifting.
- 10: By stop-down metering. Exposure is determined by presetting the lens aperture before shifting.
- 11: With AI-type Nikkor, AI-S-type Nikkor and Series E lenses having a maximum aperture of f/5.6 or faster. With the TC-16A, however, some lenses cannot be attached.
- 12: Some lens/teleconverter combinations require exposure compensation. (See teleconverter's instruction manual.)
- 13: With effective aperture of f/5.6 or faster.
- 14: Shutter should be released after determining exposure by stop-down metering with bellows.
- 15: By stop-down metering. Focusing screen compensation of +0.5 EV is required using Custom Setting #18.
- 16: Focusing screen compensation of +0.5 EV is required using Custom Setting #18.

3-4-2. Lenses/teleconverter that cannot be used with the F5

- The following lenses/teleconverter cannot be used with the F5:

Lens/teleconverter	Serial No.	Reason
Fisheye 8mm f/8	All	Cannot be attached. (Obstructed by front of camera body.)
Old-type PC 35mm f/3.5	All	Cannot be attached. (Obstructed by front of finder.)
Old-type Reflex 1000mm f/6.3	All	Cannot be attached. (Obstructed by grip position.)
AF Teleconverter TC-16	All	Cannot be attached. (Obstructed by grip position.)
80mm f/2.8 for F3AF	All	Can be attached, but too much electric current.
200mm f.3.5 for F3AF	All	Can be attached, but too much electric current.
21mm f/4	All	Cannot be attached. (Obstructed by mirror box.)

- The following lenses can be attached after modification of the meter coupling lever or AI-modification of the lens at a Nikon service facility:

Lens	Serial No.	Reason
Non-AI lens	All	Meter coupling lever obstructs. Can be attached after the lens is AI-modified (if it can be modified) or after modifying the lever.
Lens with Focusing Unit AU-1	All	Meter coupling lever obstructs. Can be attached after modifying the lever.
PC 28mm f/4	No. 180900 or below	Meter coupling lever obstructs. <b>Can be attached</b> after modifying the lever.
PC 35mm f/2.8	No. 851001 to 906200	Meter coupling lever obstructs. <b>Can be attached</b> after modifying the lever.
Reflex 1000mm f/11	No. 142361 to 143000	Meter coupling lever obstructs. <b>Can be attached</b> after modifying the lever.
Reflex 2000mm f/11	No. 200111 to 200310	Meter coupling lever obstructs. <b>Can be attached</b> after modifying the lever.
ED 180-600mm f/8	No. 174041 to 174180	Meter coupling lever obstructs. Can be attached after modifying the lever.
ED 360-1200mm f/11	No. 174031 to 174127	Meter coupling lever obstructs. Can be attached after modifying the lever.
200-600mm f/9.5	No. 280001 to 301922	Meter coupling lever obstructs. Can be attached after modifying the lever.



The following lenses/accessories can be attached under certain conditions:

Lens/accessory	Serial No.	Reason
Old-type Reflex 500mm f/8	All	Can be attached with tripod mounting collar rotated 90°.
Reprocopy Outfit PF-4	All	Requires Camera Holder Adapter PA-4.
Bellows Focusing Attachment PB-6	All	Requires attachment ring.

### 3-5. Available Type of TTL Auto Flash According to Camera's Exposure Mode

- Following shows type of TTL auto flash:

		With CPU lens		With non-CPU lens	
		P, S, A	M	A	M
With Data-communication Speedlights	FP High-Speed Sync Flash is set	FP High-Speed Sync Flash is set			
	TTL auto flash mode is set on Speedlight	With Monitor Pre-flashes	3D Multi-Sensor Balanced Fill-Flash/Multi-Sensor Balanced Fill-Flash (with Monitor Pre-flashes)		Center-Weighted Fill-Flash/Spot Fill-Flash
		Without Monitor Pre-flash	3D Multi-Sensor Balanced Fill-Flash/Multi-Sensor Balanced Fill-Flash (without Monitor Pre-flash)		
Non-TTL auto or manual flash mode is set on Speedlight/ Standard TTL Flash is required		—			
With other Speedlights	TTL auto flash mode is set on Speedlight	Multi-Sensor Balanced Fill-Flash (without Monitor Pre-flash)	Standard TTL Flash	Center-Weighted Fill-Flash/Spot Fill-Flash	Standard TTL Flash
	Non-TTL auto or manual flash mode is set on Speedlight		—		
With Speedlight turned off/ Without Speedlight		—			

### 3-6. Autofocus Using Focus-Assist Illuminator

- The focus-assist illuminator lights up when a) a Speedlight is attached to the camera's accessory shoe and turned on, b) Single Servo AF is set, c) the AF module detects that your subject is EV 5 or darker (at ISO 100)\*, d) focus is not locked, e) an AF lens is used, and the center focus area is selected.

\* Once the focus-assist illuminator lights up, it remains lit as long as the subject is brighter than EV 5.

Note 1: Focus-assist illuminator lights up regardless of AF area mode.

Note 2: Focus-assist illuminator lights up regardless of film advance mode.

Note 3: Focus-assist illuminator lights up regardless of metering system. In Spot Metering, autofocussing may be slightly inaccurate.

### 3-7. 1/300 TTL High-Speed Sync

- Custom Setting functions enable you to select 1/300 TTL High-Speed Sync. With 1/300 TTL High-Speed Sync, the Speedlight guide number is fixed at 12. 1/300 TTL High-Speed Sync is only available with the shutter speed set to X-setting.
- 0.3ms after the X contact is turned on, the flash automatically stops firing. The full-open time is  $0.675 \pm 0.391$ ms.
- The flash stops firing when TTL auto flash is complete, even it takes less than 0.3ms.
- If TTL auto flash is not completed within 0.3ms, the viewfinder ready-light blinks (at 4 Hz) for four seconds. When this happens, the ready-light on the Speedlight does not blink, and the underexposure alert does not appear inside the viewfinder.
- In Programmed and Aperture-Priority Auto exposure mode, the fastest flash sync speed is 1/250 sec. and 1/300 TTL High-Speed Sync is not available. Another TTL Flash sync speed can be selected using Custom Setting #20.
- If the camera determines that TTL auto flash mode or FP High-Speed Sync is not set on the Speedlight, the flash synchronizes at 1/250 sec. without canceling 1/300 TTL High-Speed Sync.

## 4. FILM OPERATION

### 4-1. Loading Film and Advancing Film to Frame One

- When the shutter is released with the camera back open, the spool is duty-driven for a specified time to advance and wind the film (if the film leader has been pressed). (Described as blank film advance.)
- The film winding time for blank film advance depends on the temperature. Duty ratio depends on voltage.
- With the film leader positioned to the film index mark inside the spool chamber and the camera back closed, when the shutter release button is fully depressed the film advances three frames to frame one then the spool motor automatically stops. The frame counters on top of the LCD panel and inside the viewfinder, which showed E before film advance, show 1 after film advance. If "data imprinting on frame #0" is selected using the Custom Setting function via PC Link, the frame counter shows 0.
- Without film loaded, fully depressing the shutter does not advance film.
- While advancing the film to frame one, the camera performs duty-driving until the first film-advance-completion switch shifts from L to H, whereupon it then performs full-driving. It carries out this operation regardless of film advance mode.
- If three film-advance-completion signals are not input within a specified time after film advance starts, the camera judges that a film-loading error has occurred. The alert LED blinks (at 1 Hz), and **Err** blinks (at 1 Hz) in place of the shutter speed indication in the top LCD panel and inside the viewfinder.
- With no film loaded, and before advancing the film to frame one, the frame counter on the top LCD panel and inside the viewfinder shows **E**.
- The frame counter shows frame numbers up to 39. (For 39 frames and beyond, the counter continues to show "**39**".)

### 4-2. Film End Detection

- After the spool motor starts rotating, if the film-advance-completion signal is **not input** within 2 sec. in CS mode or within 1 sec. in other film advance modes, the spool motor stops. The alert LED lights up, and **End** blinks (at 1 Hz) in place of the shutter speed indication in the top LCD panel and inside the viewfinder. When the camera's exposure meter is turned off, the **End** indications stop blinking.  
Using the auto film stop (at 35th or 36th frame) option available in Custom Setting #12, the alert LED and LCD panel/viewfinder indications are same as the indications that appear when the camera reaches the end of roll film without the auto film stop option.

### 4-3. Film Rewinding

- Auto film rewind is performed by a dedicated film rewind motor.
- Auto film rewind starts when both R1 and R2 knobs are set with the camera's power on.
- Auto film rewind is possible before reaching the end of the film roll.
- During auto film rewind, the alert LED blinks (at 1 Hz).
- Auto film rewind stops when the camera power is turned off or when the R2 knob is reset.
- Film can be manually rewound by setting the R1 knob then rotating the film rewind crank. Manual film rewind is possible at any time, regardless of available camera power.

- When **film rewind** is complete, frame counter shows 0 then E. For auto film rewind, frame counter shows E when timer is off after film-detect switch is on. For manual film rewind, frame counter shows E immediately after film-detect switch is on.
- 10 sec\* after auto film rewind begins, film rewind automatically stops. In this case, the alert LED blinks (at 1 Hz) and Err blinks (at 1 Hz) in place of the shutter speed indication in the top LCD panel and inside the viewfinder.  
\* 10 sec. is fixed regardless of the type of power source.
- When auto film rewind is complete, the camera's meter turns off.

#### 4-4. Film Advance Speed (Shooting Speed)

Battery	Film advance mode	Drive system	Shooting speed*
Ni-MH	CH	Parallel	(8.2 fps)
			6
	CL	Series	5
			4
			(3)
CS	Series (PWM)	1	
AA-type	CH	Parallel	(7.4 fps)
			6
	CL	Series	4.7
			4
			(3)
CS	Series (PWM)	1	

\* Can be changed using Custom Setting function. Figure in bracket shows **default shooting speed**..

### 5. FOCUSING SCREEN

#### 5-1. Focusing Screen Contacts

- Seven contacts are provided—five segment-drive contacts, a GND contact and an identify contact.
- Contacts are located as follows:

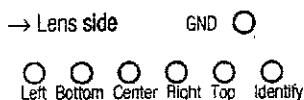

(Seen from finder box)

## 6. FINDER

### 6-1. Finder Contacts

- 13 finder contacts are provided on the front side of the finder, as follows:

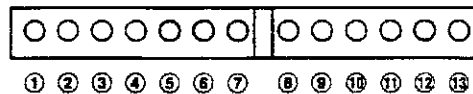

- |                             |                          |
|-----------------------------|--------------------------|
| ① GND                       | ⑧ ILPW                   |
| ② Control contact           | ⑨ TTL stop contact       |
| ③ Control contact           | ⑩ Monitor signal contact |
| ④ +12V power supply contact | ⑪ Ready signal contact   |
| ⑤ +3.3V contact             | ⑫ Sync contact           |
| ⑥ Control contact           | ⑬ SBGND contact          |
| ⑦ Control contact           |                          |

→ Film take-up side

## 7. POWER SOURCE

- AA-type alkaline-manganese, lithium batteries can be used.
- AA-type manganese, NiCd batteries cannot be used. They can, however, be installed.
- The battery holder is designed so that power is not supplied if batteries are improperly installed (if batteries installed in the wrong direction).

## 8. DATA BACK CONTACTS

- Data back contacts are provided on the bottom rail below the film take-up spool chamber.

- |                                   |
|-----------------------------------|
| ① Power supply line contact (+6V) |
| ② Meter-on/release signal contact |
| ③ Data imprint signal contact     |
| ④ Input signal contact            |
| ⑤ Output signal contact           |
| ⑥ DCI/O signal contact            |
| ⑦ Clock contact                   |
| ⑧ GND contact                     |

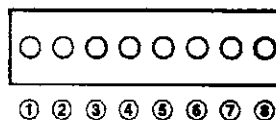

- With the standard camera back attached, contacts ④ to ⑦ (input signal contact, output signal contact, DCI/O signal contact and clock contact) are used as focus area contacts—contact ④ for top, contact ⑤ for left, contact ⑥ for bottom and contact ⑦ for right.

## **9. MODIFYING CAMERA**

- The following modifications can be performed by service facilities.
  - a) Modification to prevent film from being completely rewound.
  - b) EPROM upgrade.
  - c) Modification of meter coupling lever, enabling it to be set to the "up" position.

# 10. TIME CHARTS

■AE/AF

13.5V±0Ω  
(Ni-MHx10) CH mode  
Unit (msec)

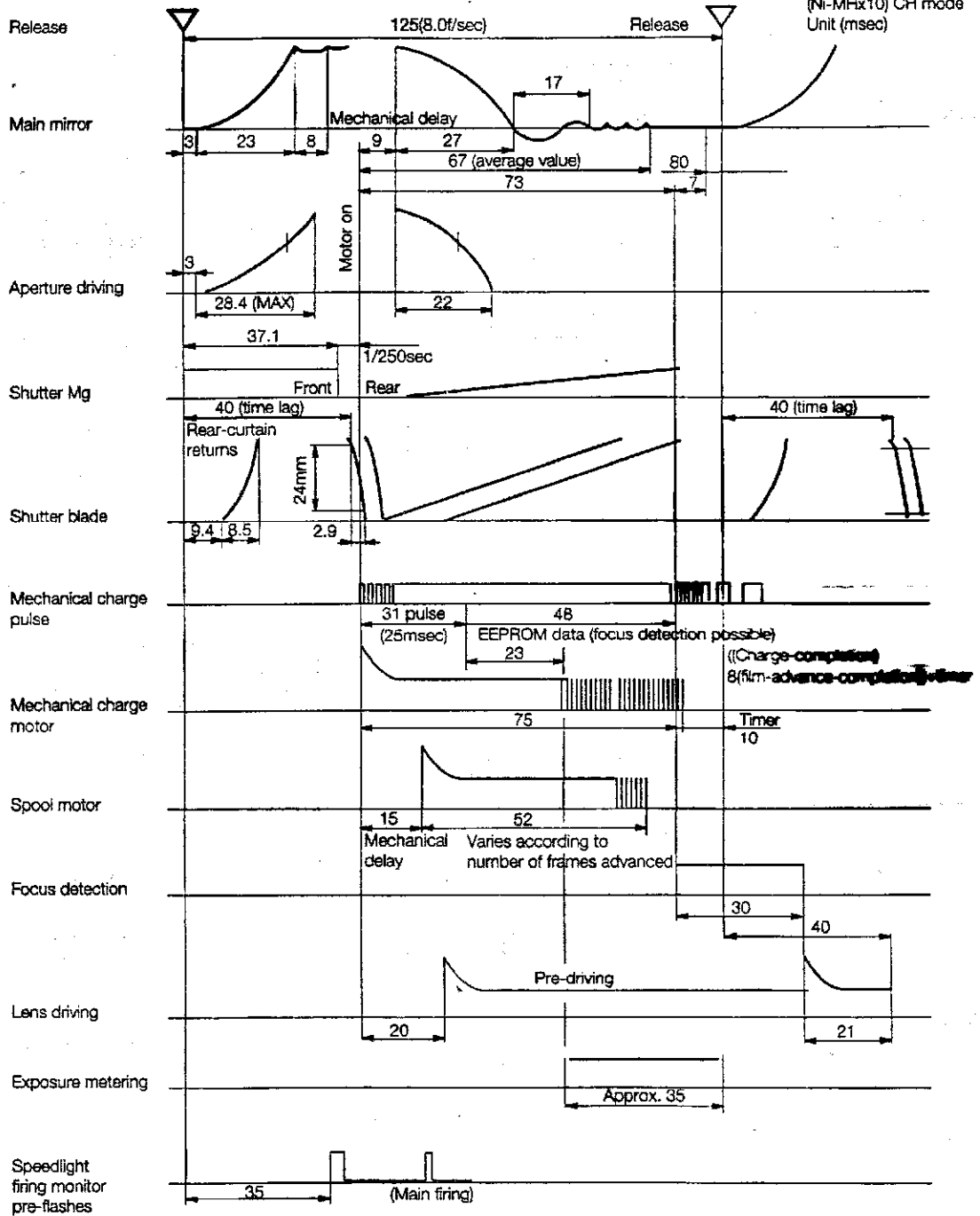

■ CH mode (with Ni-MH Battery Unit)

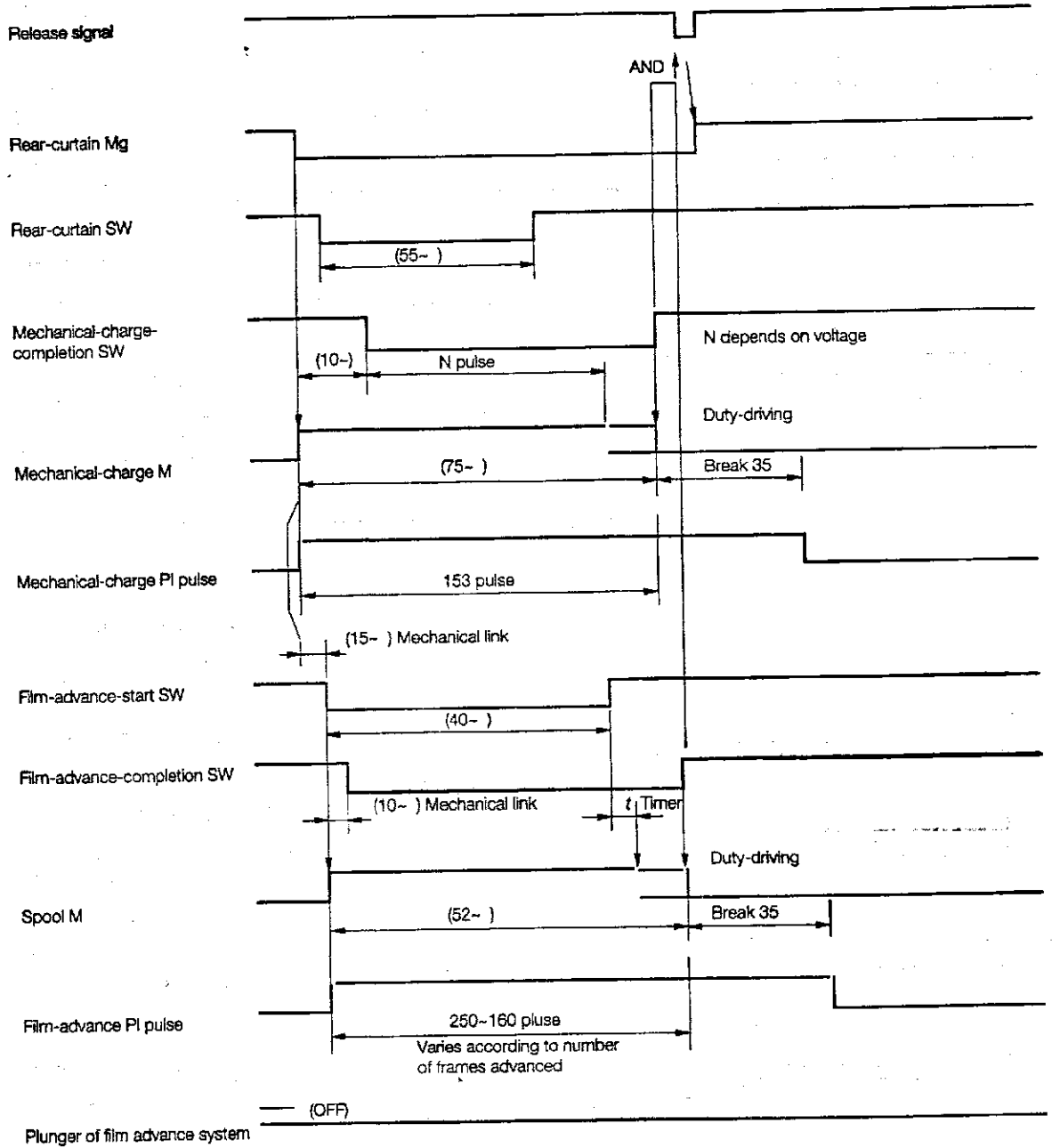



■ CL mode (with Ni-MH Battery Unit)

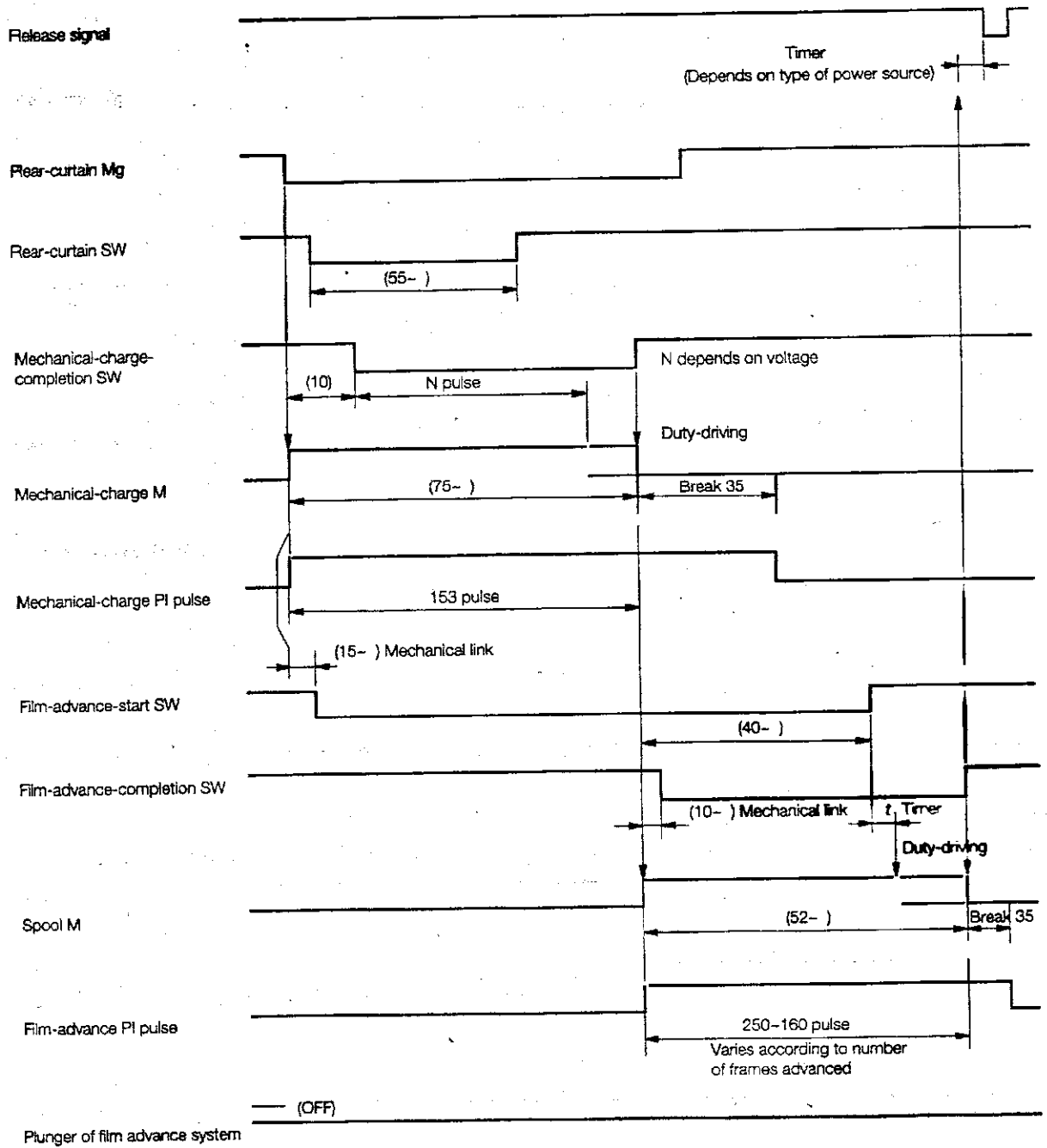

■CS mode (with NF-MH Battery Unit)

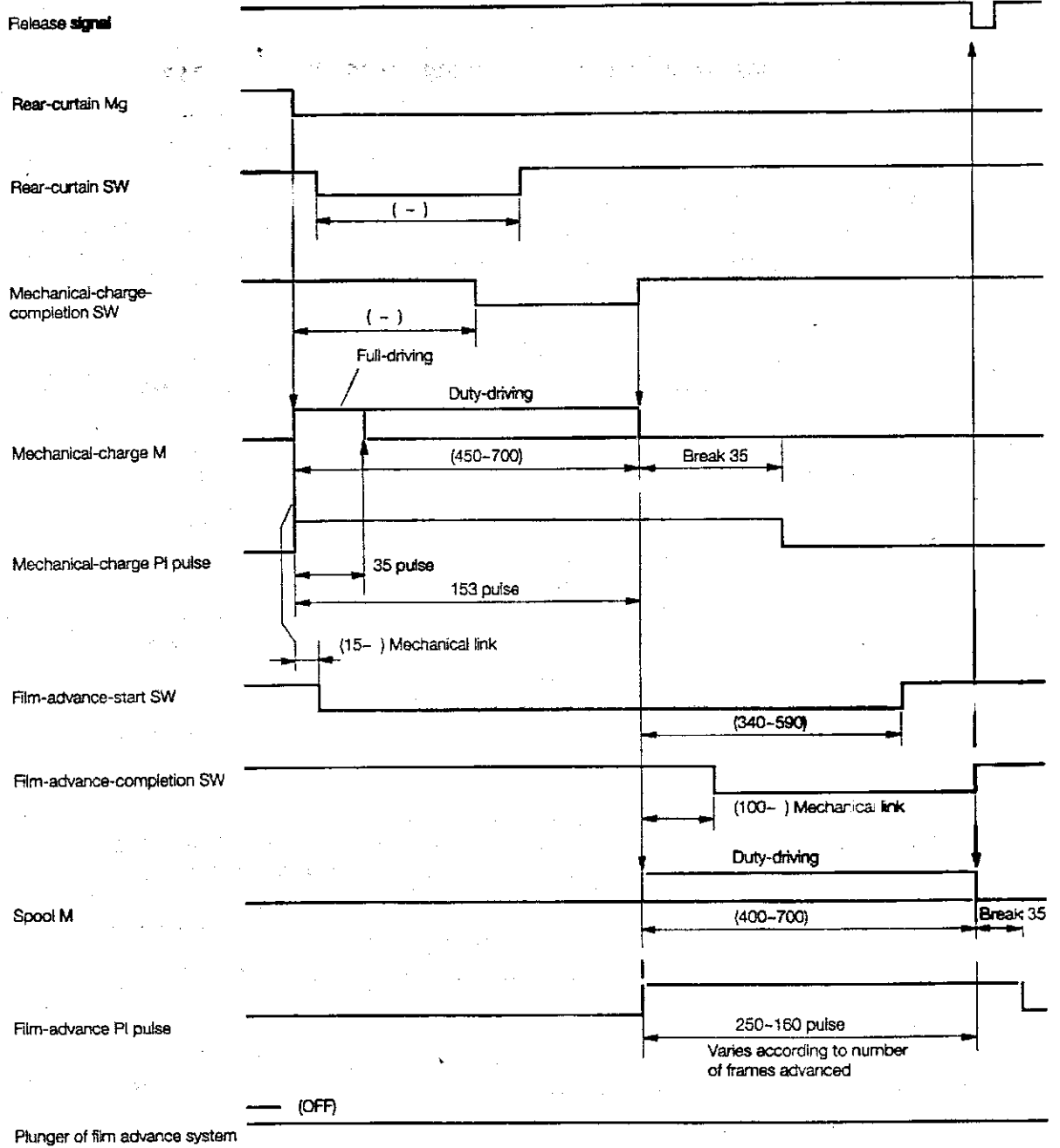

# DISASSEMBLE

## 1. DISASSEMBLING REAR BODY AND FRONT BODY UNIT

RUBBER ARMORED EXTERNAL BODY .....	D 1
BODY GRIP .....	D 1
BOTTOM COVER .....	D 2
BATTERY CHAMBER BARRIER PLATE .....	D 3
TOP COVER ON FILM ADVANCE SIDE .....	D 4
TOP COVER ON FILM REWIND SIDE .....	D 4
FRONT BODY .....	D 5

## 2. DISASSEMBLING REAR BODY

CONNECTOR, REMOVING SOLDERING WIRES .....	D 6
MAIN BASE PLATE .....	D 7
DC-DC BASE PLATE .....	D 7
BACK DISPLAY BASE PLATE .....	D 8
FILM REWIND BASE PLATE .....	D 9
FILM REWIND SHAFT BASE PLATE .....	D 10
DX CONTACT PFC .....	D 11
CHARGE LARGE LEVER, FILM ADVANCE STOP RELEASE LEVER .....	D 11
R1 RELAY LEVER .....	D 12
SHUTTER .....	D 12
CHARGE BASE PLATE GROUP .....	D 13
FILM ADVANCE BASE PLATE, EL ROLLER .....	D 14
R1 SWITCH .....	D 14
R1 LEVER GROUP .....	D 15
DATA CONTACT UNIT, F DETECT SWITCH .....	D 15
R2 LEVER, CLUTCH LEVER .....	D 16
R1 BUTTON COVER BASE PLATE, AF-S SWITCH .....	D 16
SMALL PARTS OF REAR BODY .....	D 17

## 3. DISASSEMBLING FRONT BODY

REMOVING FD RAIL .....	D 18
REMOVING LIGHT BAFFLE PLATE AT THE REAR OF THE MAIN MIRROR .....	D 18
REMOVING CONNECTORS ON AAF BASE PLATE .....	D 18
REMOVING CORDS ON AF BASE PLATE .....	D 19
REMOVING AF BASE PLATE .....	D 20
LENS RELEASE BASE PLATE .....	D 20
REMOVING AP4 UNIT .....	D 20
REMOVING FRONT SIDE DISPLAY MOLD .....	D 21
FD CONTACT MOLD .....	D 21
SCREEN CONTACTS UNIT & SC CONTACTS .....	D 22
MANUAL MUP GUIDE PLATE .....	D 22
REMOVING LENS RELEASE SWITCH .....	D 23
REMOVING f-to PULLY .....	D 23
LENS RELEASE BUTTON COLLAR SPRING .....	D 24
REMOVING MIRROR BOX UNIT .....	D 24
REMOVING DRIVING BASE PLATE .....	D 25
REMOVING AF MODE SWITCHING LEVER .....	D 25
REMOVING EMBNET UNIT .....	D 26
AF LENS CONTACT .....	D 26
REMOVING I BASE PLATE .....	D 27

# DISASSEMBLE

## 1. Disassembling rear body and front body units.

Rubber armored external body

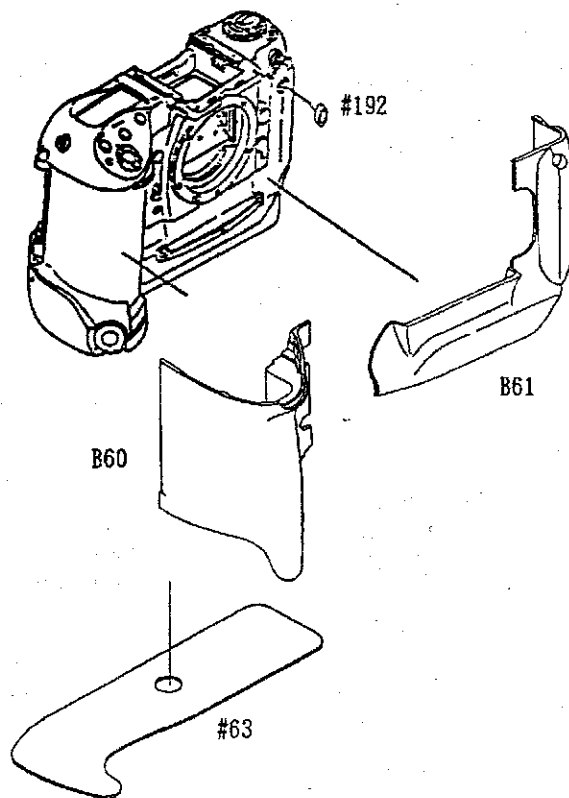

Body grip

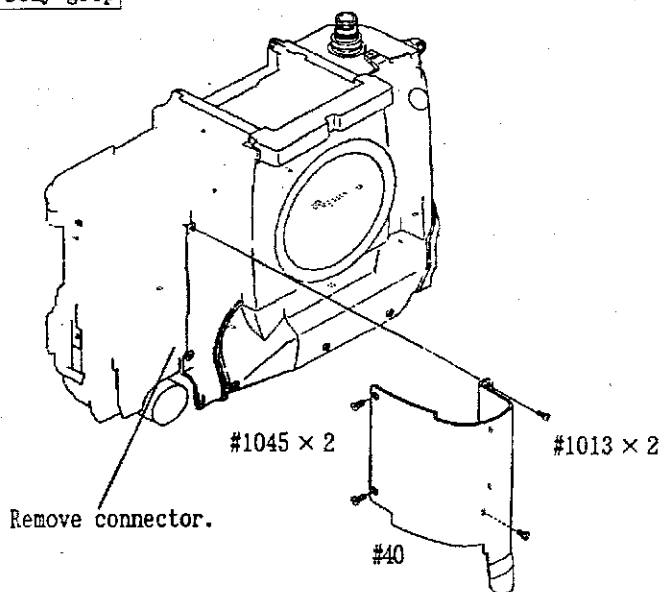

**Bottom cover**

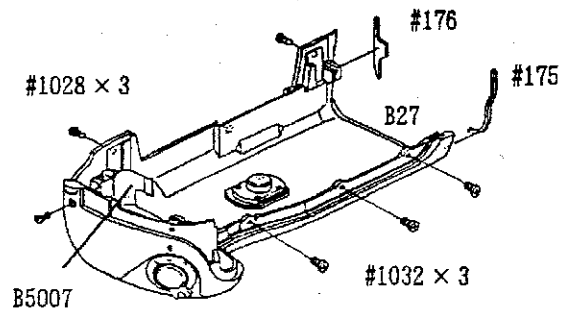
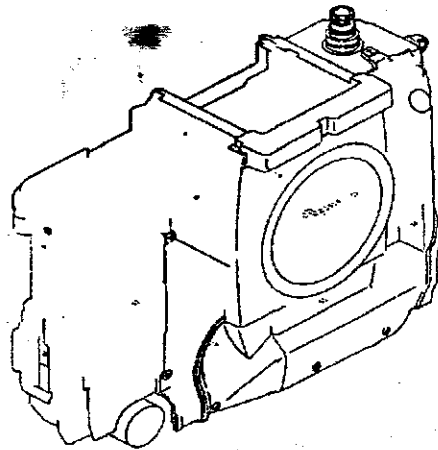

Remove bottom cover FPC (B5007) from connector.

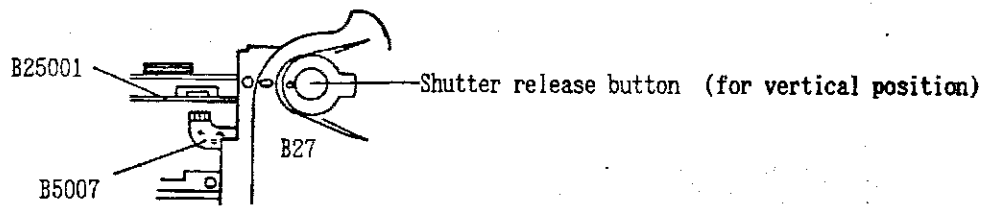

Bottom cover FPC

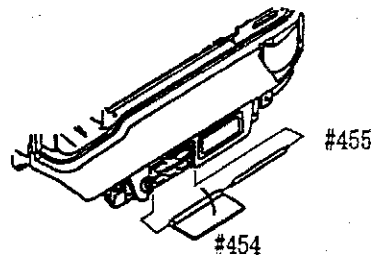

**Battery chamber barrier plate**

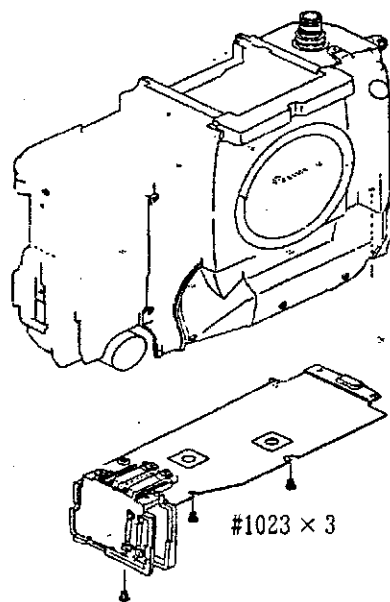
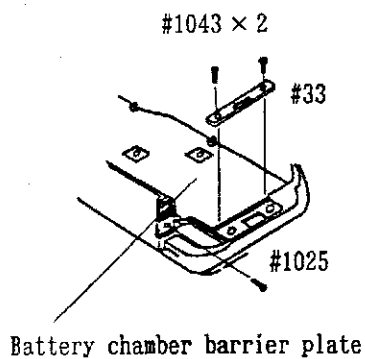
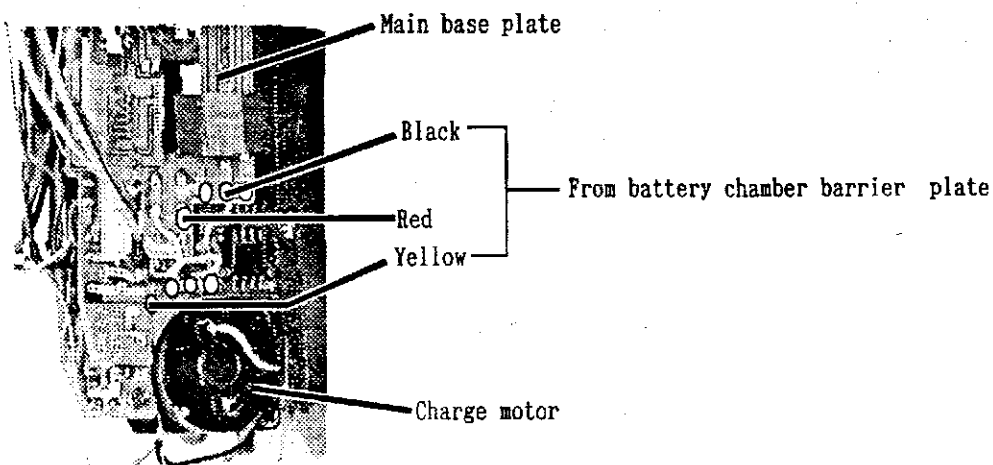
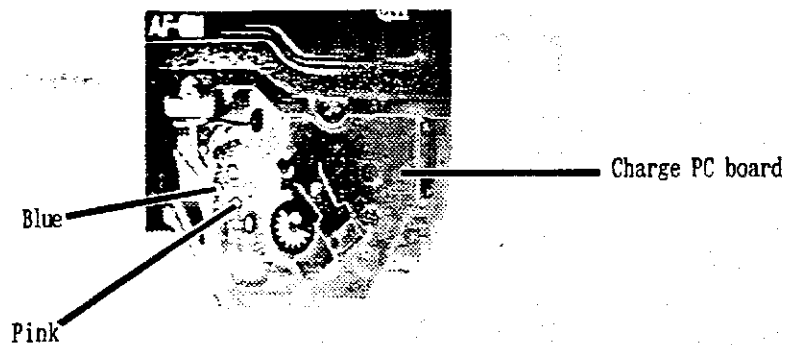

Top cover on film advance side

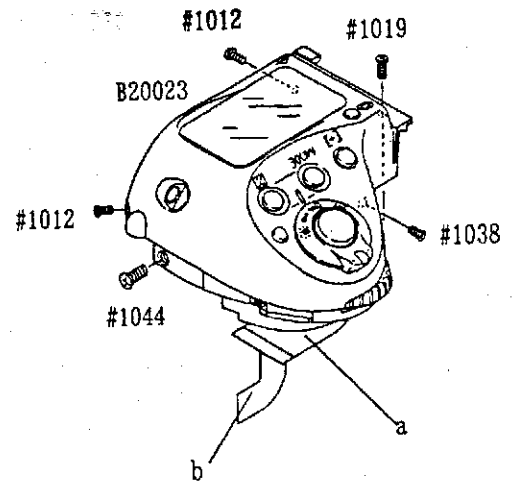
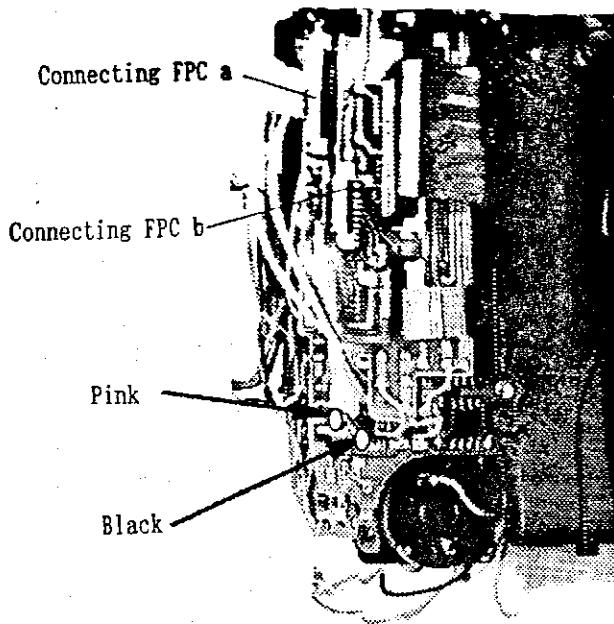

Top cover on film rewind side

